

Laboratory 1

Relational database design

Goal

The goal of this laboratory activity is the conceptual and logical design of relational databases. In particular

Exercises 1-6: starting from some informal specifications, it is required to:

1. perform the conceptual design of the database through the E-R diagram;
2. restructure the E-R diagram, if necessary, to remove composite attributes, multi-valued attributes and generalizations;
3. translate the restructured E-R diagram to the corresponding relational logical schema.

Exercise 7: starting from the E-R diagram, it is required to:

1. restructure the E-R diagram, if necessary, to remove composite attributes, multivalued attributes and generalizations;
2. translate the restructured E-R diagram to the corresponding relational logical schema;
3. specify the integrity constraints for two relations of your choice.

The conceptual design through the E-R diagram, the restructuring of the E-R diagram (if needed), and the translation of the E-R diagram into the corresponding relational logical schema can be performed by means of the **designER** software. The website at the address <https://designerdb.io/> provides:

- 1) **the link to designER (full version)**. designER supports:
 - a. conceptual design (E-R graphical representation, with additional support in correctly using the E-R constructs);
 - b. E-R diagram restructuring;
 - c. translation to the corresponding relational model.
- 2) **a video tutorial on the functionalities of designer;**
- 3) **the link to designER basic**. designer ER basic only allows to draw the E-R diagram and does not include additional functionalities and checks.

Exercise 1: Management of company relocations

You are requested to design the database for the management of company relocations. The database must contain a list of vans suitable for relocations. The vans are identified by their plate, and they are characterized by their model and, if known, by their volume in cubic meters. Of all the vans, some are authorized to transport special materials, and only for such vans, a list with the certifications of the special materials known to be allowed has to be stored. The database must contain a list of warehouses, identified by a code and characterized by their address and the name of the company to which they belong. You are requested to keep track of all the relocations made. The relocations are identified by the date and by the van with which they are made, and they are characterized by the name of the driver who carried it out. Each relocation is also characterized by the departure warehouse and departure time, and by the arrival warehouse and arrival time.

Exercise 2: Management of van repairs

You are requested to design the database for the management of van repairs. The database must contain a list of vans identified by their plate and characterized by the year of registration. Among the several types of vans, the capacity of the battery is known for those equipped with an electric motor. The database must also include the list of repair shops, identified by a unique code, and characterized by their address. The repair shops can be in partnership with some companies. For each partner company, its VAT number, name, and possibly the list of telephone numbers is known. Note that each company can be in partnership with multiple repair shops and you are requested to keep track only of those companies having a partnership. You are also requested to keep track of the repairs carried out over time on each van. The date, cost and duration in hours are known for each repair. Note that a van can undergo multiple repairs on the same day but in different repair shops. A repair shop can carry out at most one repair for the same van on the same day.

Exercise 3: Management of rental contracts

You are requested to design the database for the management of rental contracts. The database must contain a list of properties available for rent. The properties are identified by a land code, they are characterized by the address, the area in square meters and the list of rooms. Among the different properties available, for the apartments, the floor number is known. The database must contain a list of agencies, identified by a code, and characterized by the address and the list of phone numbers. You are requested to keep track of all the rental contracts of the agencies for each property. Different rental contracts may have been stipulated for the same property, with the same agency or with different agencies. A rental contract is characterized by a start date and an end date, by a monthly price, and can be renewable or non-renewable. A property can only have one rental contract for the same time period. A contract is associated with a single property and a single agency.

Exercise 4: Management of real estate agent mandates

You are requested to design the database for the management of agent mandates at some real estate agencies. The database must contain a list of agents. Agents are identified by the Tax ID, they are characterized by their full name, the telephone number, and they may have an e-mail address. Each agent covers one or more geographical areas. Every geographical area is identified by the main city and it is characterized by the list of possible other municipalities included in the area, by the total number of inhabitants, and by the territorial area in square kilometers. The database must contain a list of real estate agencies. Real estate agencies are identified by a unique identifier, and they are characterized by an address. Agencies can be either independent or franchised. For what it concerns independent agencies, the Tax ID of the business owner is known. Regarding the franchised agencies, only the name of the retail chain which they belong to is known. You are requested to keep track of all the mandates that agencies gave to their agents. An agent can be given more mandates from the same agency at separate times. An agency may have given more mandates to the same agent at different times. An agent can simultaneously have mandates from different agencies. You are requested to keep track of the start date, the end date, and the type of each mandate.

Exercise 5: Management of staff shifts in company buildings

You are requested to design the database for the management of staff shifts in different company buildings. The database must contain a list of employees. Employees are identified by a unique code within the company, they are characterized by their name, email address, and the list of qualifications. Employees can be either factory workers or clerks; for clerks their role is known. The database must contain the list of the company buildings, which are identified by a unique code and characterized by their address and the list of telephone numbers. You are requested to keep track of all the work shifts of each employee at the various buildings. A work shift is characterized by a date, a start time and an end time, the building where it takes place, and it can be either ordinary or overtime. A shift is associated with only one employee and one building. The same employee can have work shifts in different buildings; however, an employee can work only one shift on each day.

Exercise 6: Management of maintenance inspections

We want to design the database for the management of maintenance inspections executed by workers at different machinery. The database must contain a list of workers. The workers are identified by a unique code and are characterized by their name, surname, and may have a telephone number. Each worker is assigned to one or more products. Each product is identified by the bar code and is characterized by the list of categories to which it belongs, the duration in hours of its production process and the cost. The database must contain a list of machinery. Each machinery is identified by a unique code and is characterized by a brand and a model. The machinery can be either production machinery or quality control machinery. For production machinery, the maximum energy consumption is known. The quality parameter is known for quality control machinery. You are requested to keep

track of all the maintenance inspections that workers have carried out on the various machinery. A worker can carry out multiple inspections on the same machinery at different times. A machinery can receive multiple inspections from the same worker at different times. At the same time, a worker can have multiple inspections on different machinery in progress. You are requested to keep track of the start date and time, and the end date and time of each inspection.

Exercise 7

Given the following Entity-Relationship diagram:

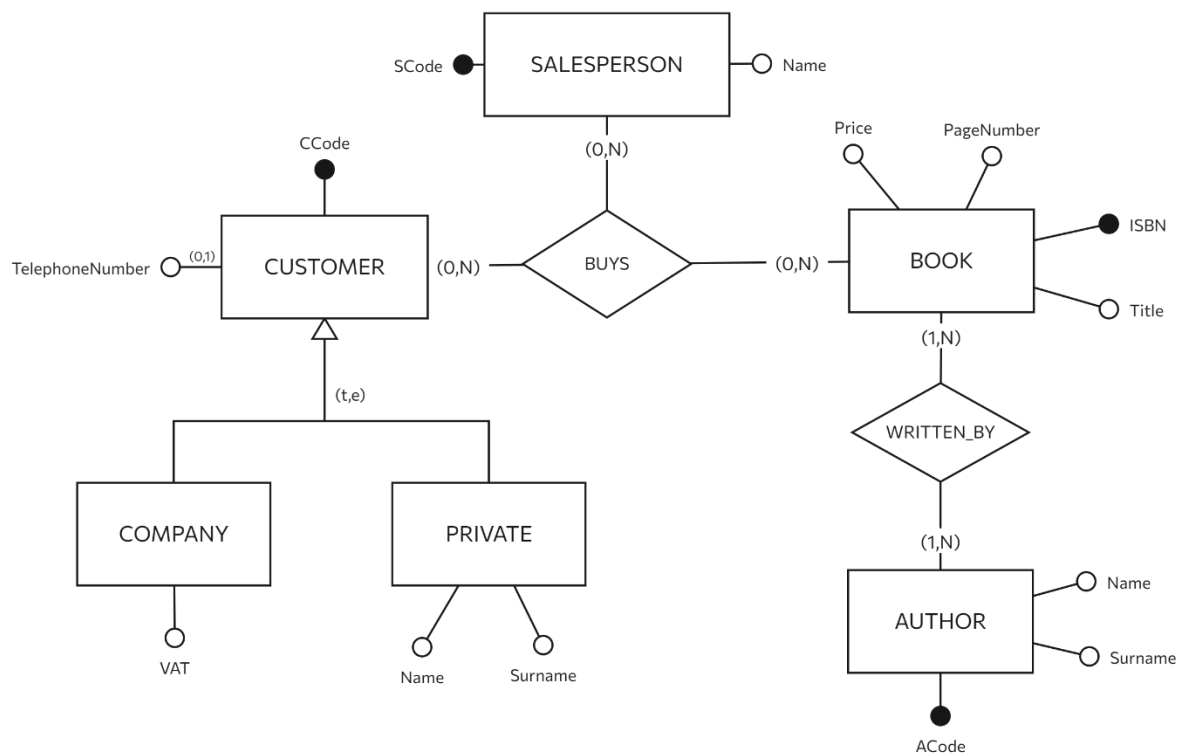

You are required to:

- Provide a normalized relational logical schema for the same database;
- Define referential integrity constraints for 2 relationships of your choice among those defined in the conceptual schema.

Draft Solution

Exercise 1: Management of company relocations

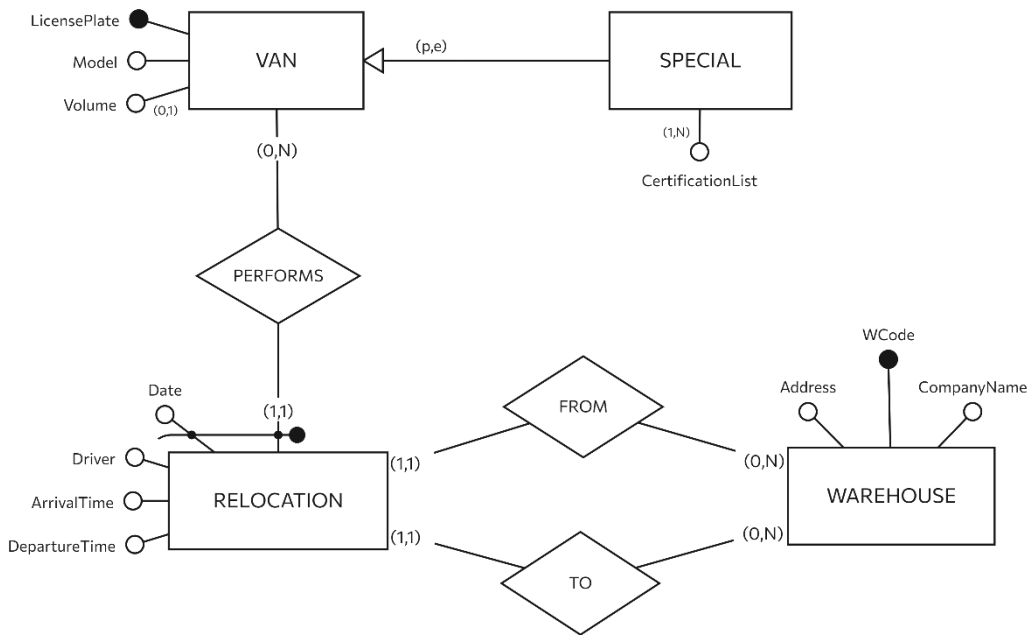

Exercise 2: Management of van repairs

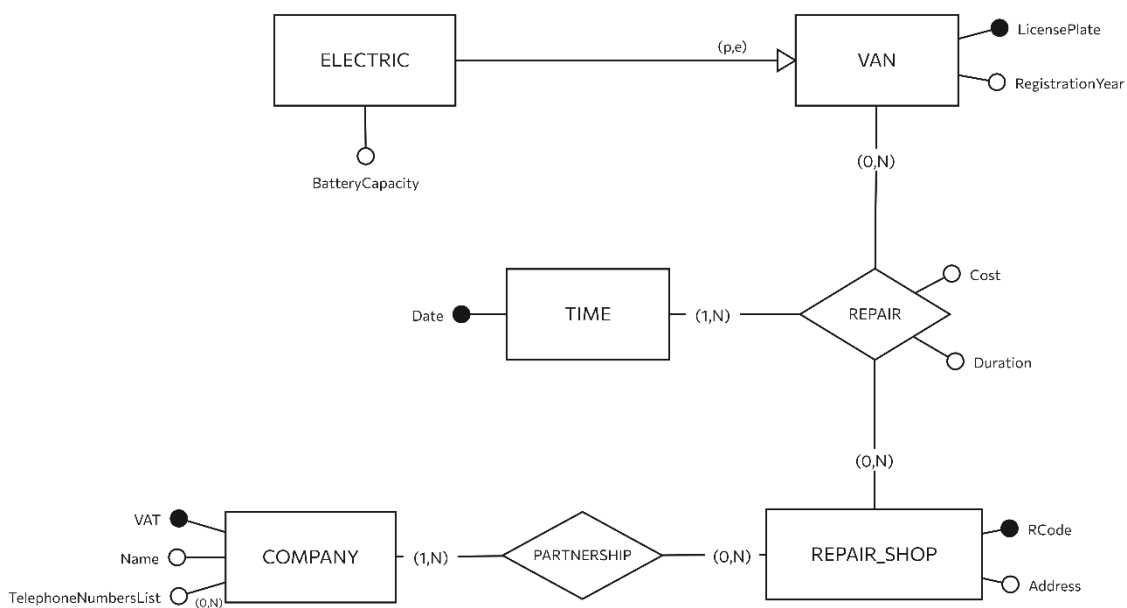

Exercise 3: Management of rental contracts

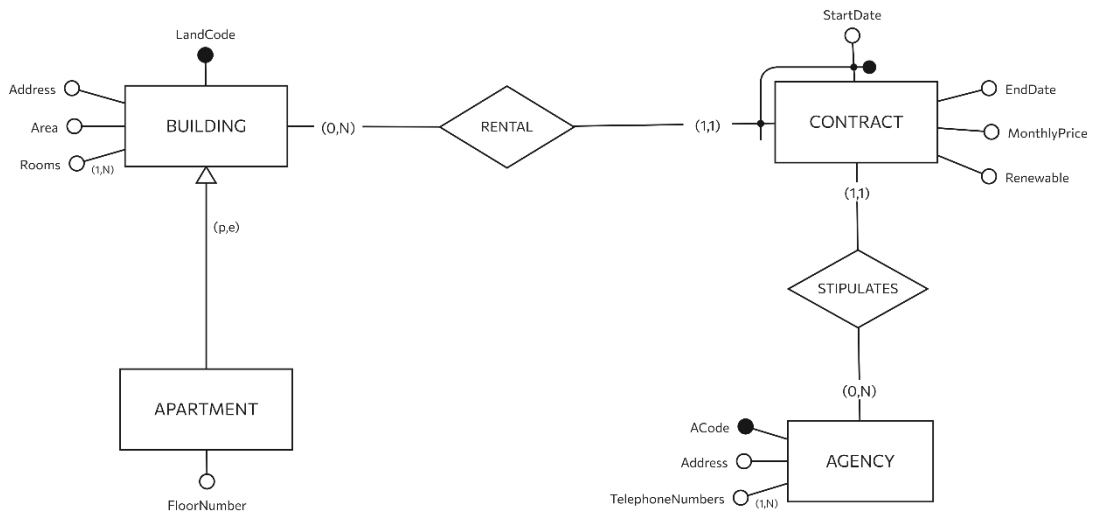

Exercise 4: Management of real estate agent mandates

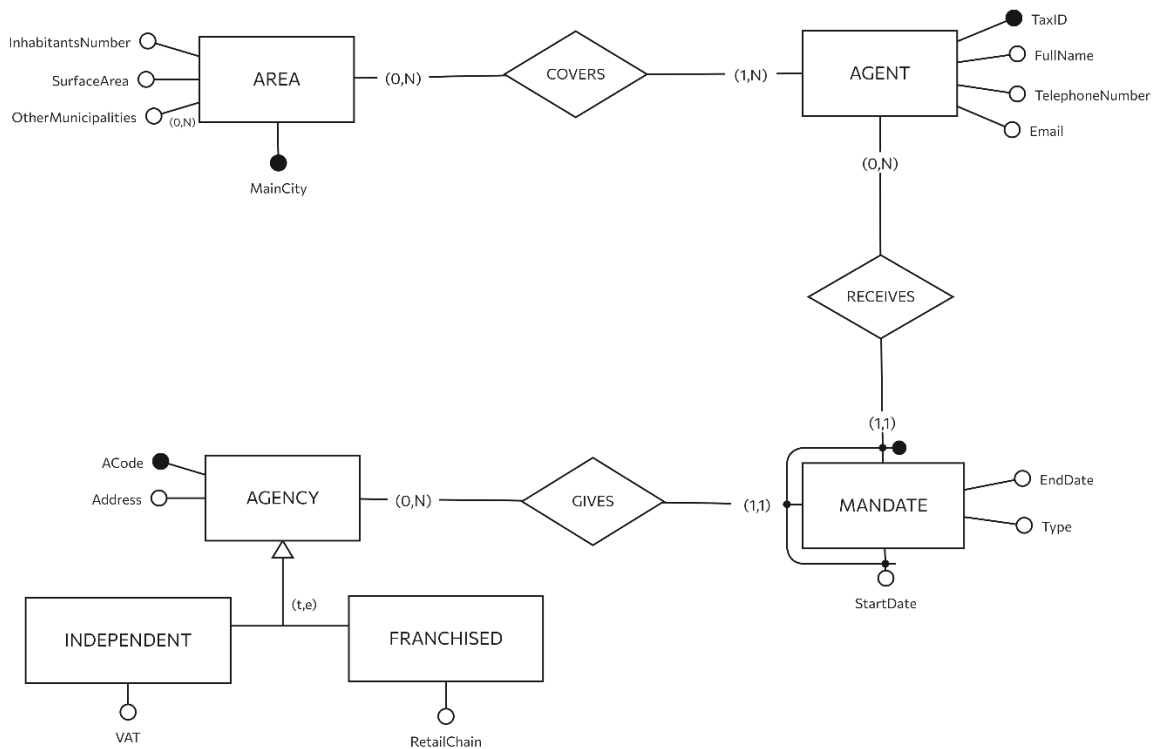

Exercise 5: Management of staff shifts in company buildings

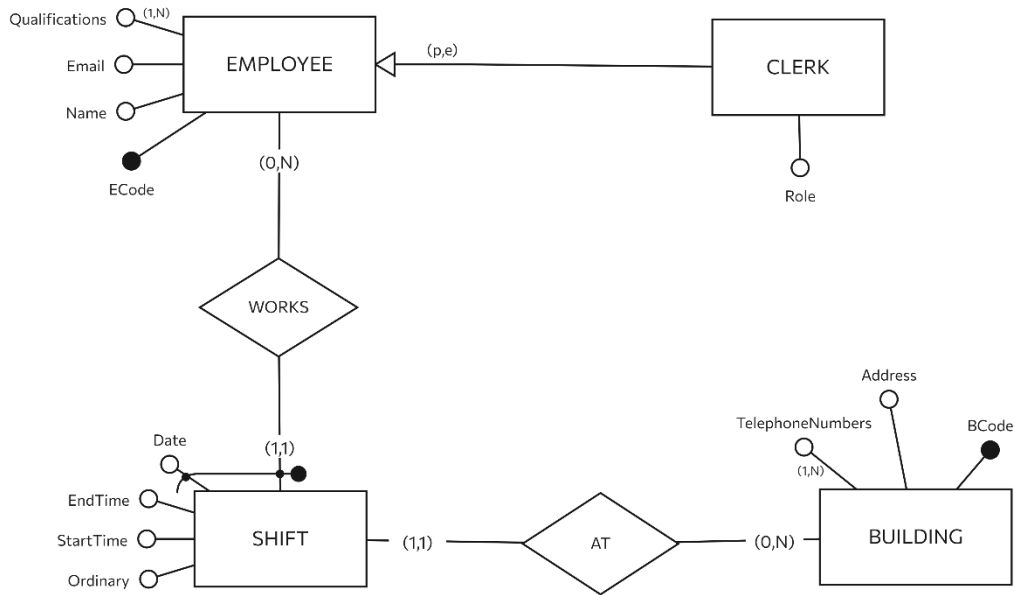

Exercise 6: Management of maintenance inspections

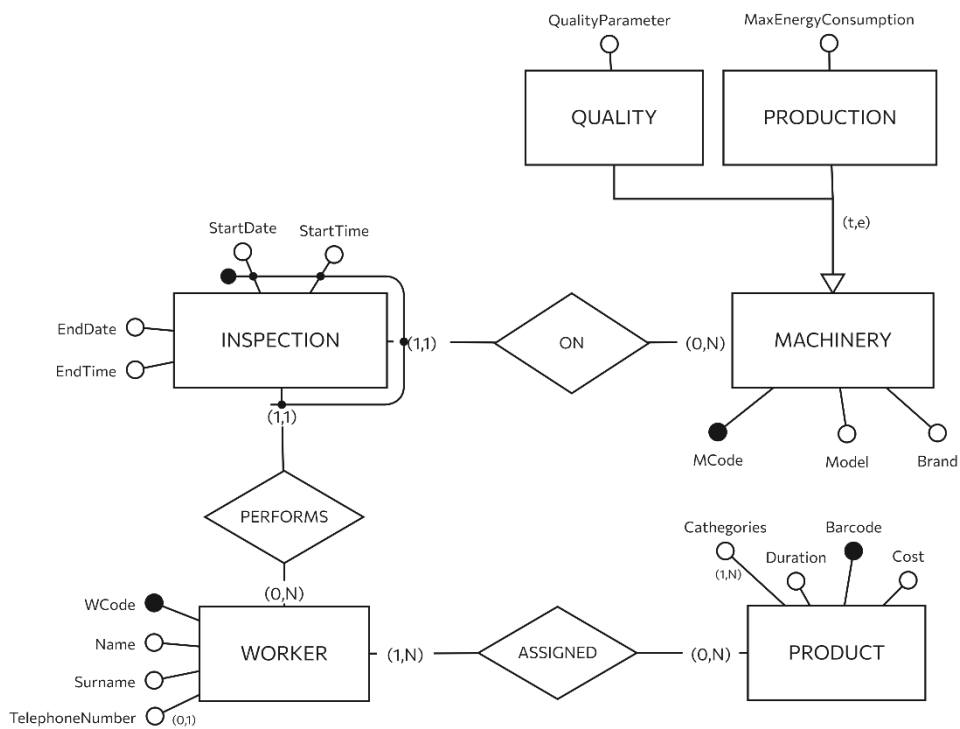

Exercise 7**Relational logical schema**

AUTHOR(ACode, Name, Surname)

BOOK(ISBN, Title, PageNumber, Price)

WRITTEN_BY(ACode, ISBN)

SALESPERSON(SCode, Name)

CUSTOMER(CCode, TelephoneNumber*, Type, Name*, Surname*, VAT*)

BUYS(CCode, SCode, ISBN)

Referential integrity constraints:

1) WRITTEN_BY(ACode) REFERENCES AUTHOR(ACode)

WRITTEN_BY(ISBN) REFERENCES BOOK(ISBN)

2) BUYS(CCode) REFERENCES CUSTOMER(CCode)

BUYS(SCode) REFERENCES SALESPERSON(SCode)

BUYS(ISBN) REFERENCES BOOK(ISBN)