



Politecnico
di Torino

DBG
MG

Relational algebra exercises



Politecnico
di Torino



Exercise 1

Exercise 1a

Exercise 1. Given the relational schema including the following tables (primary keys are underlined):

MAGAZINE (MId, MName, Publisher)

ARTICLE (AId, Title, Topic, MId)

Find the names of the magazines that have published at least one article about motorcycles.

Exercise 1a

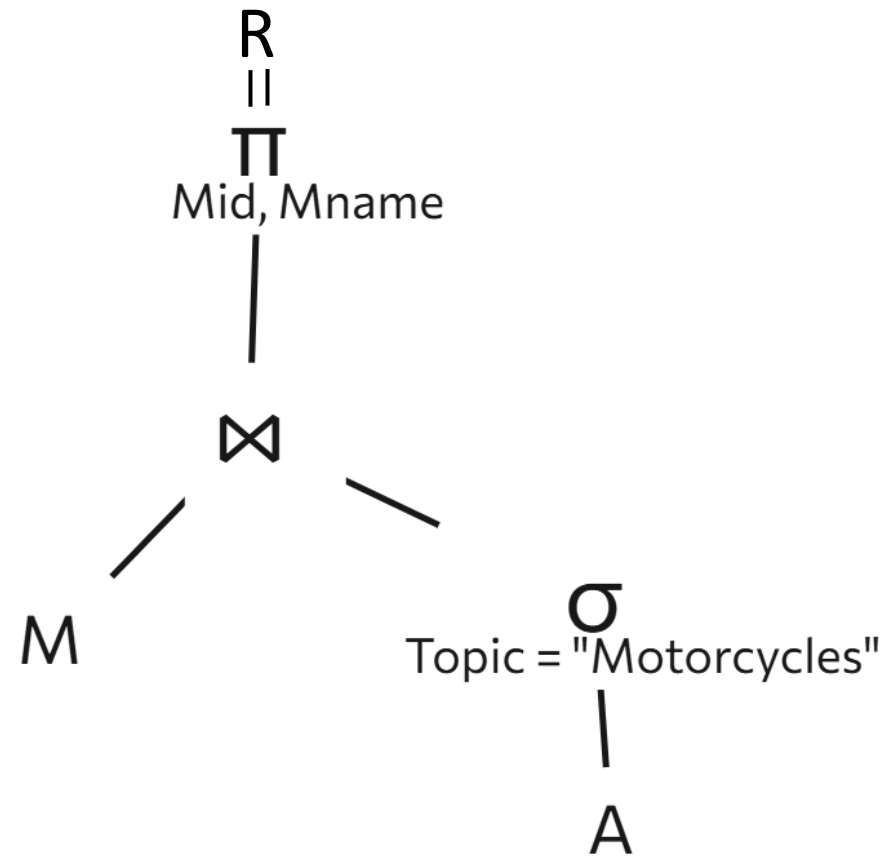

Exercise 1b

Given the relational schema including the following tables (primary keys are underlined):

MAGAZINE (MId, MName, Publisher)

ARTICLE (AId, Title, Topic, MId)

Find the names of the magazines that have never published any article about motorcycles.

Exercise 1b

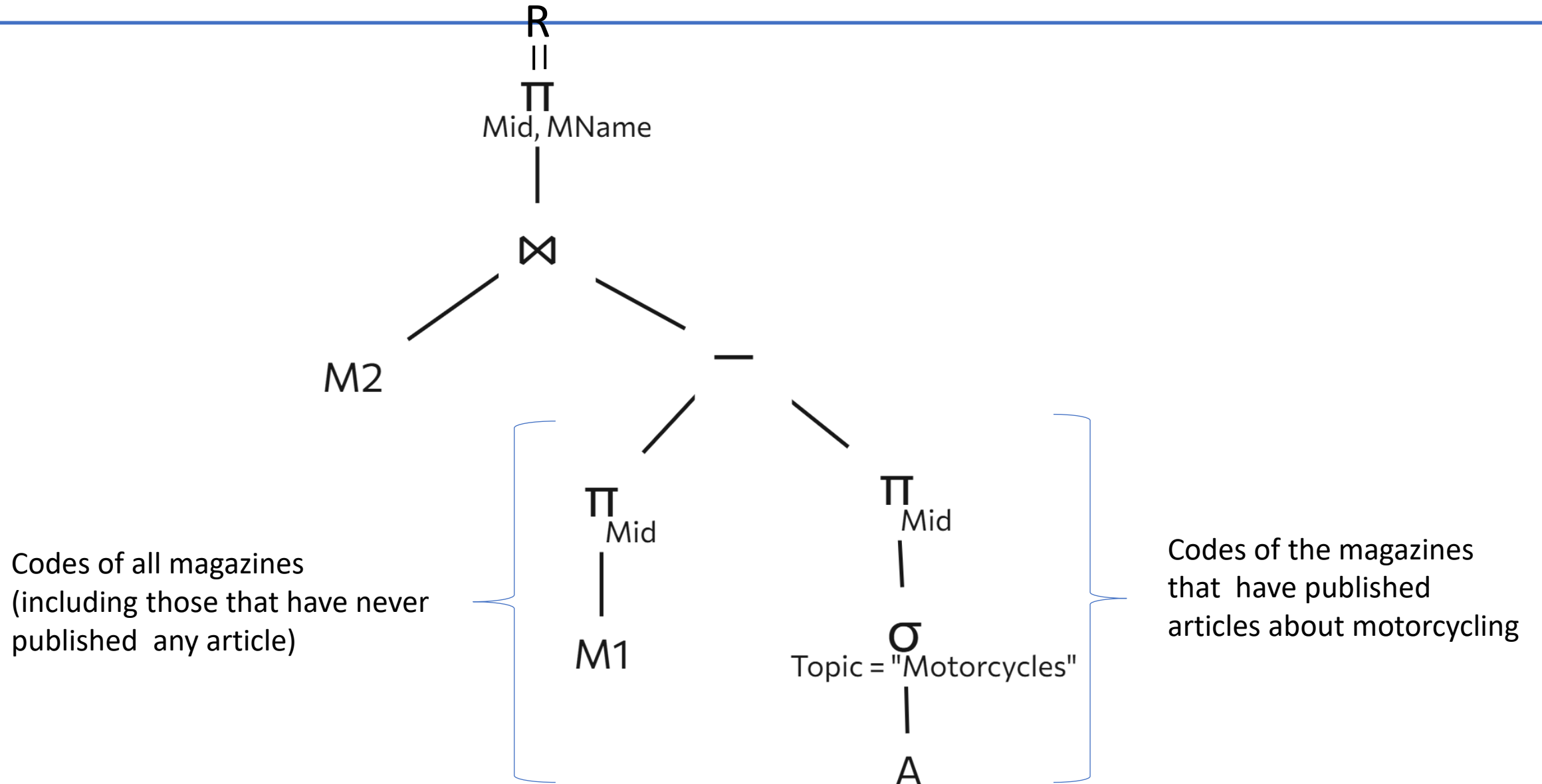

Exercise 1b

- Alternative solution

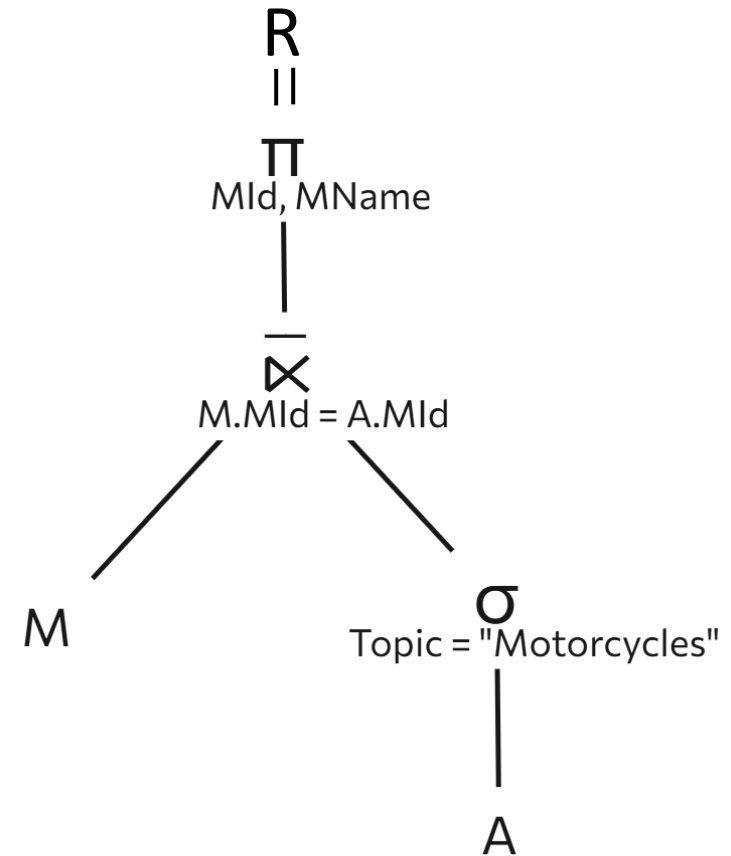

Exercise 1c

Given the relational schema including the following tables (primary keys are underlined):

MAGAZINE (MId, MName, Publisher)

ARTICLE (AId, Title, Topic, MId)

Find the names of the magazines that have only ever published articles about motorcycles

Exercise 1c

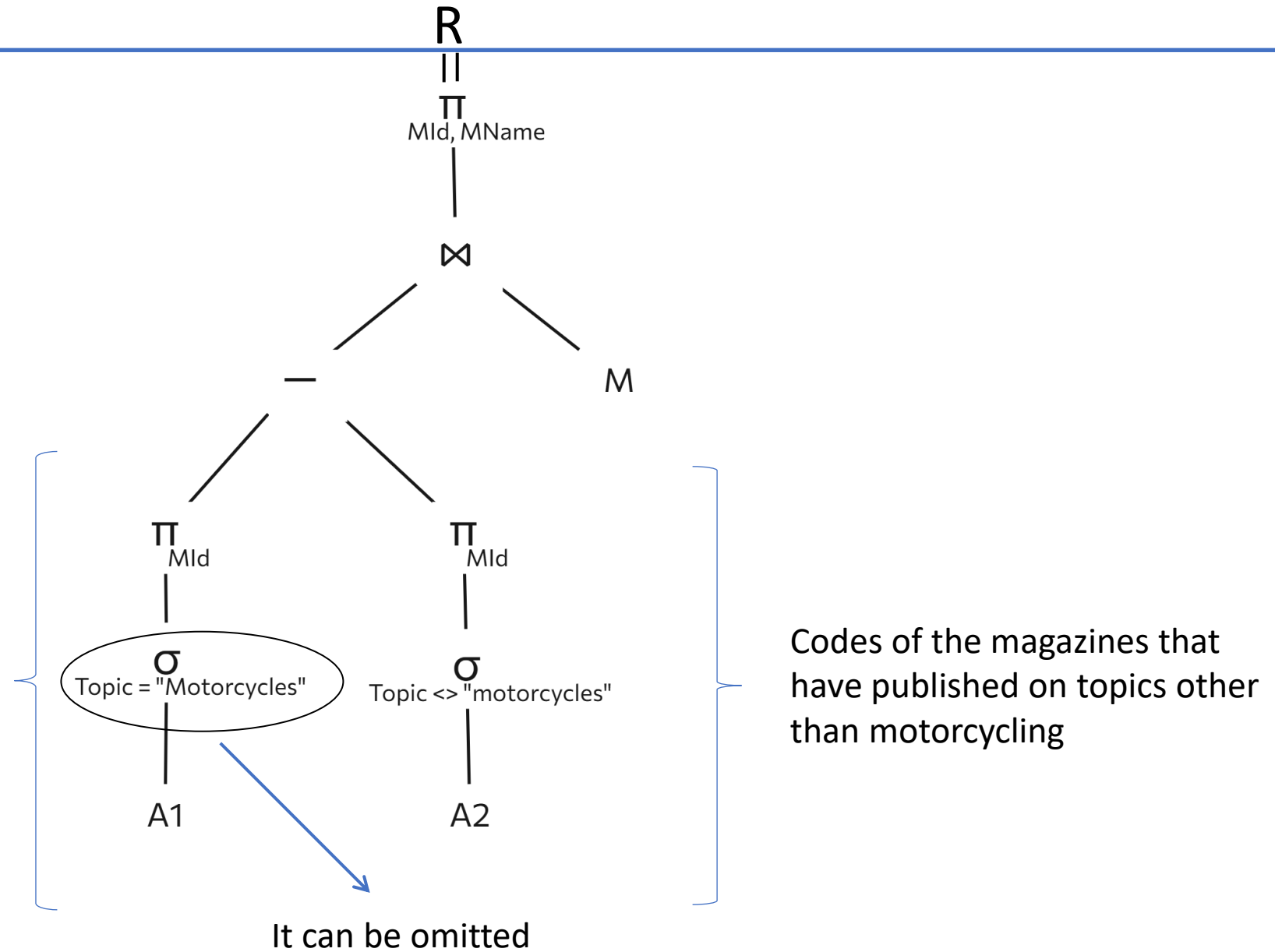

Exercise 1c

- Alternative solutions:

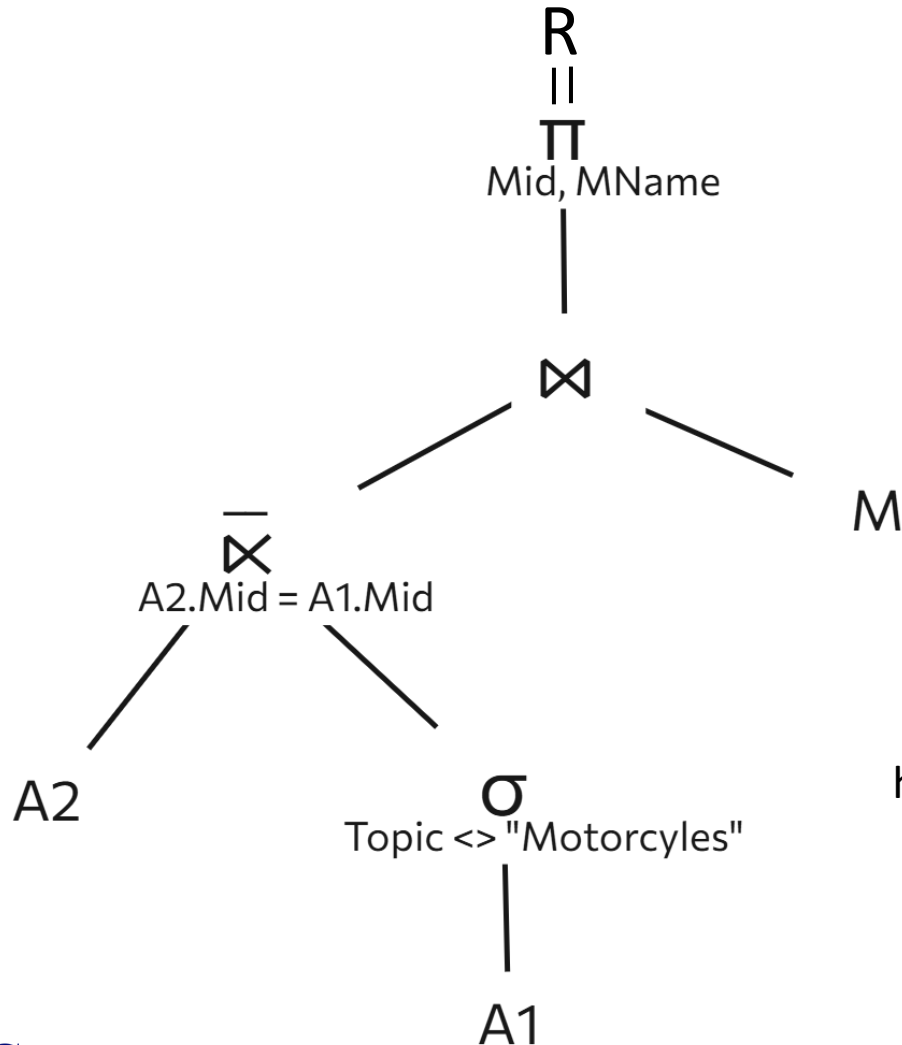

Magazines that
have published at
least one
article

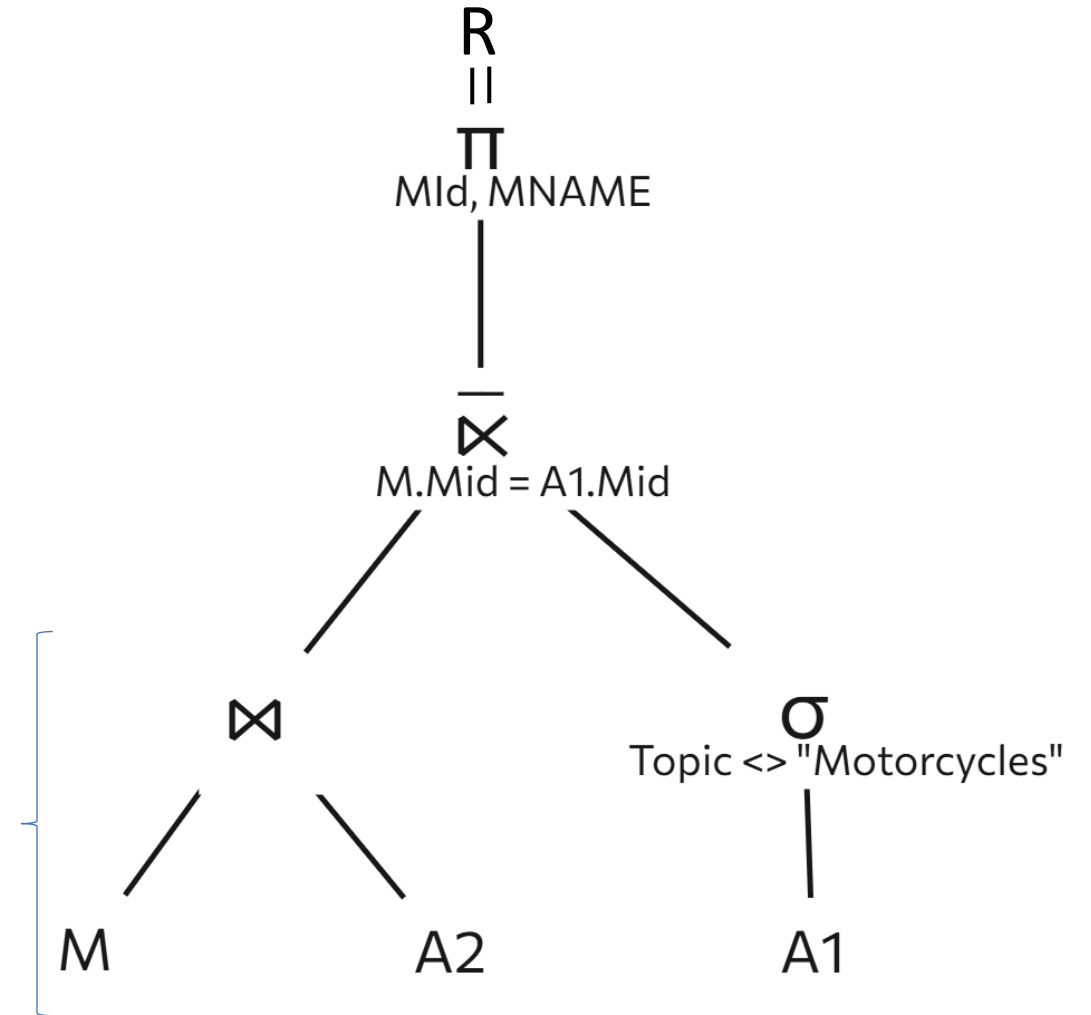

Exercise 1d

Given the relational schema including the following tables (primary keys are underlined):

MAGAZINE (MId, MName, Publisher)

ARTICLE (AId, Title, Topic, MId)

Find the names of the magazines that publish articles about motorcycles or cars

Exercise 1d

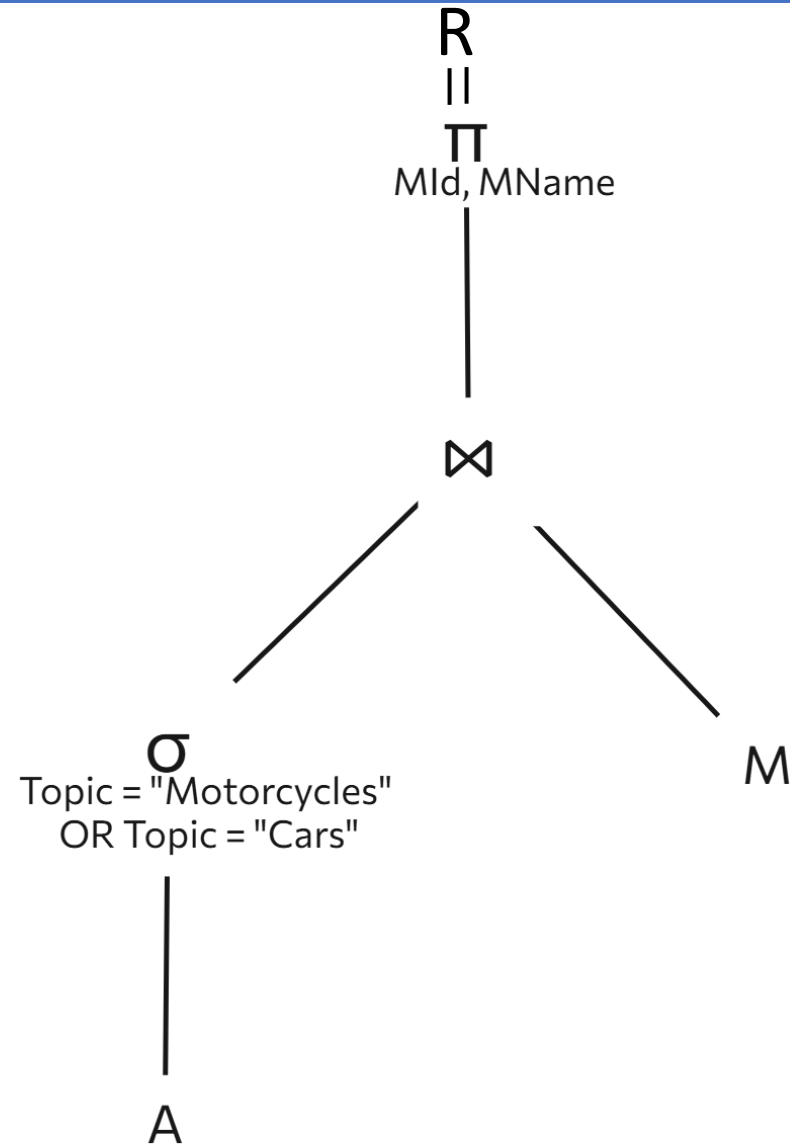

Exercise 1e

Given the relational schema including the following tables (primary keys are underlined):

MAGAZINE (MId, MName, Publisher)

ARTICLE (AId, Title, Topic, MId)

Find the names of the magazines that publish both articles about motorcycles and articles about cars.

Exercise 1e

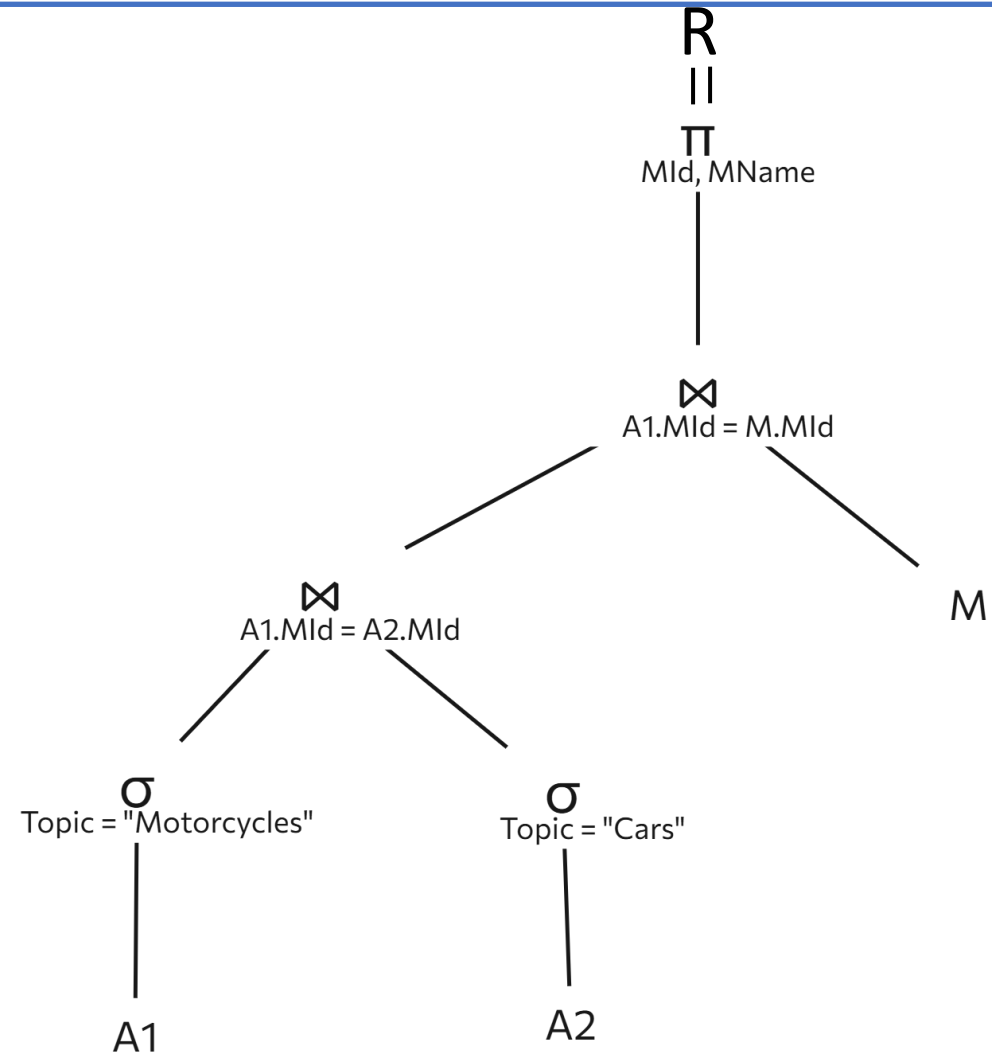

Exercise 1e

- Alternative solutions:

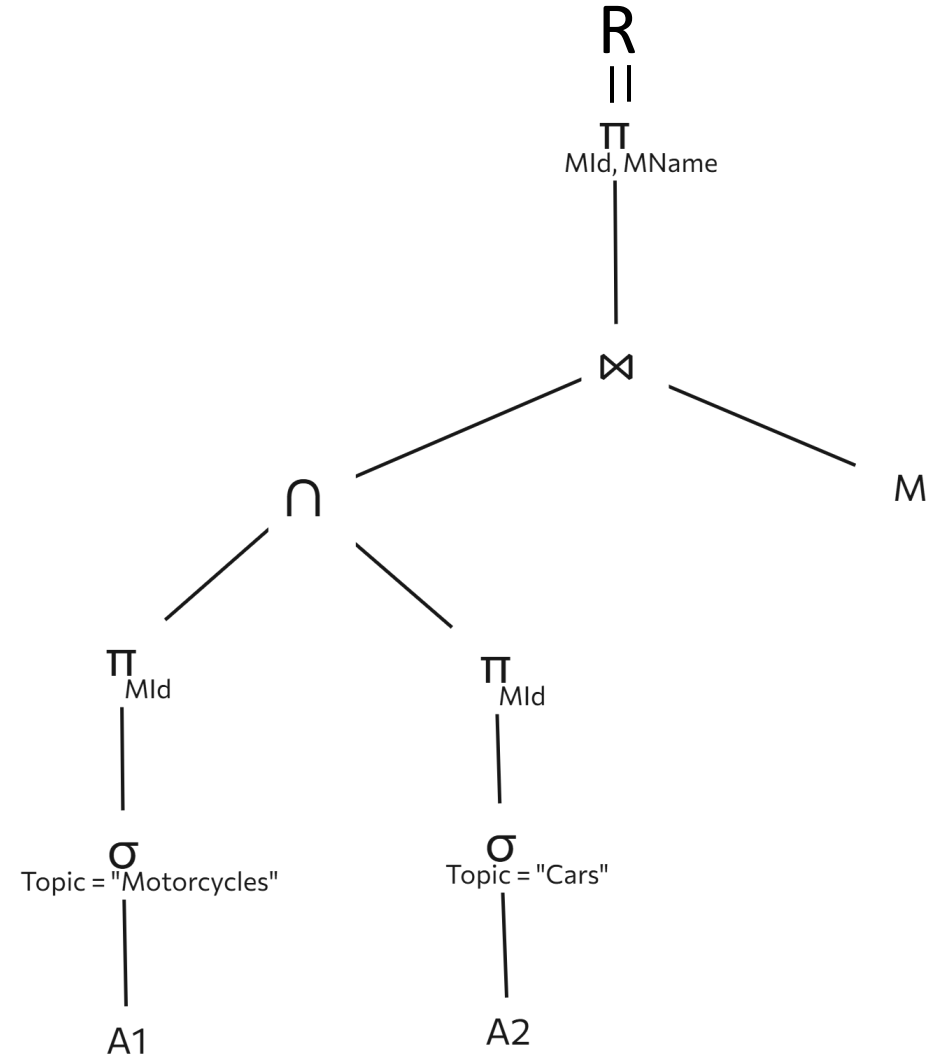
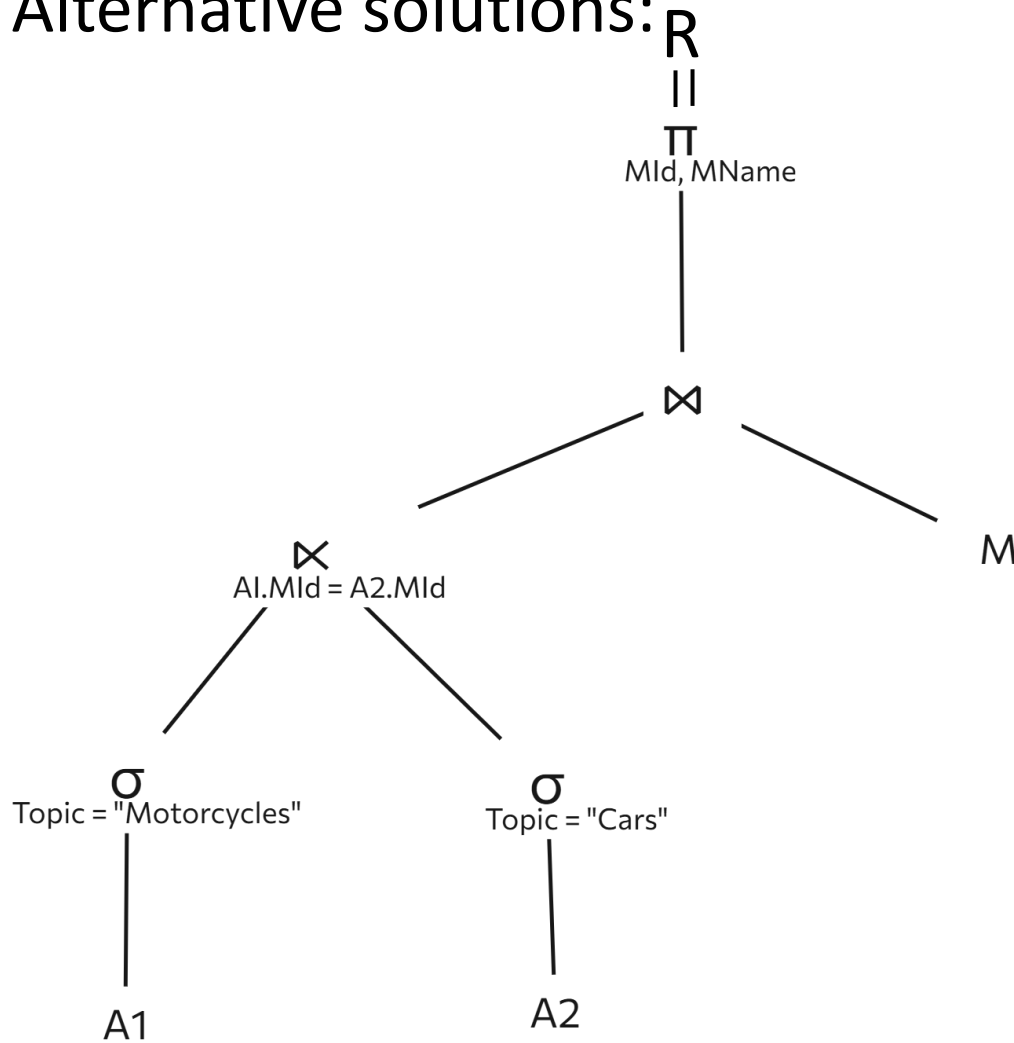

Exercise 1f

Given the relational schema including the following tables (primary keys are underlined):

MAGAZINE (MId, MName, Publisher)

ARTICLE (AId, Title, Topic, MId)

Find the names of the magazines that have published at least two articles about motorcycles.

Exercise 1f

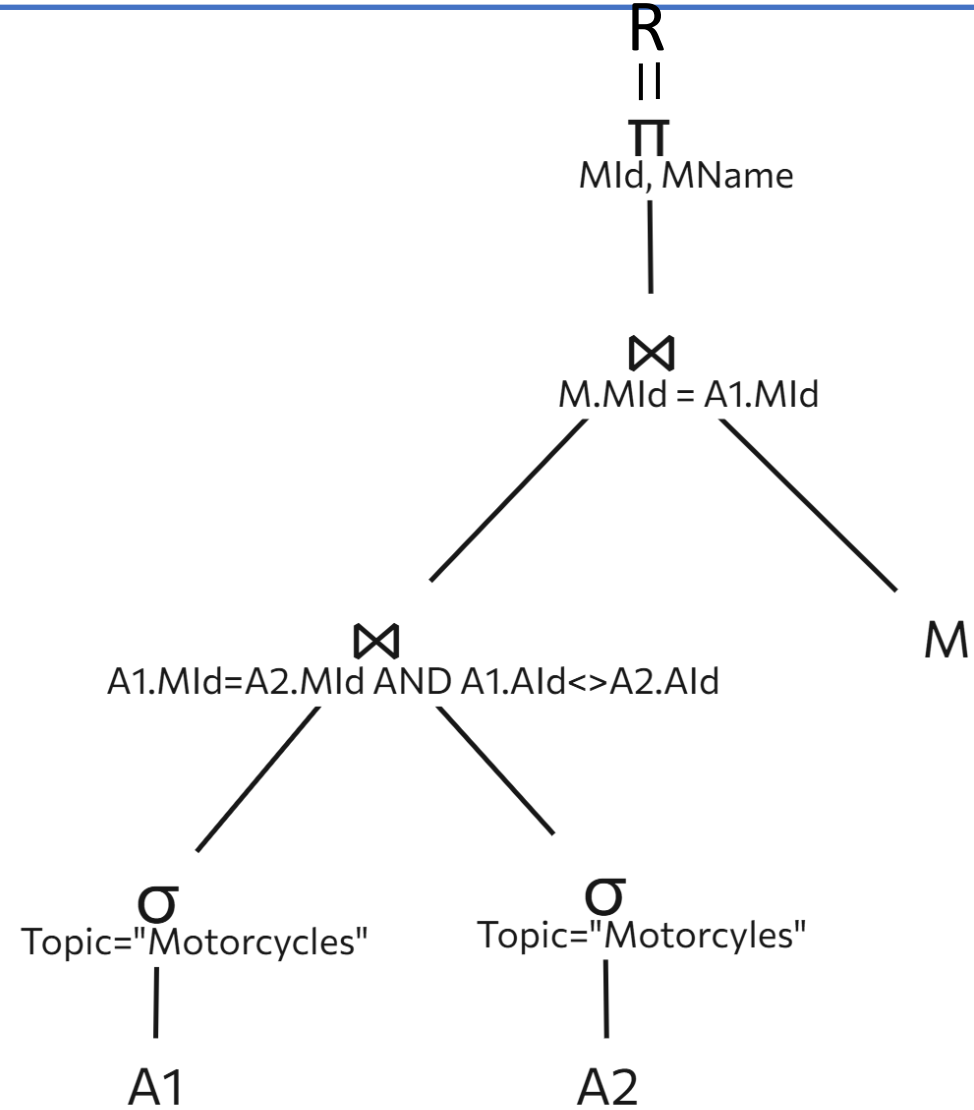

Exercise 1g

Given the relational schema including the following tables (primary keys are underlined):

MAGAZINE (MId, MName, Publisher)

ARTICLE (AId, Title, Topic, MId)

Find the names of the magazines that have published only one article about motorcycles (i.e., they may have published any number of articles about other topics).

Exercise 1g

Magazines that have published at least one article about motorcycling

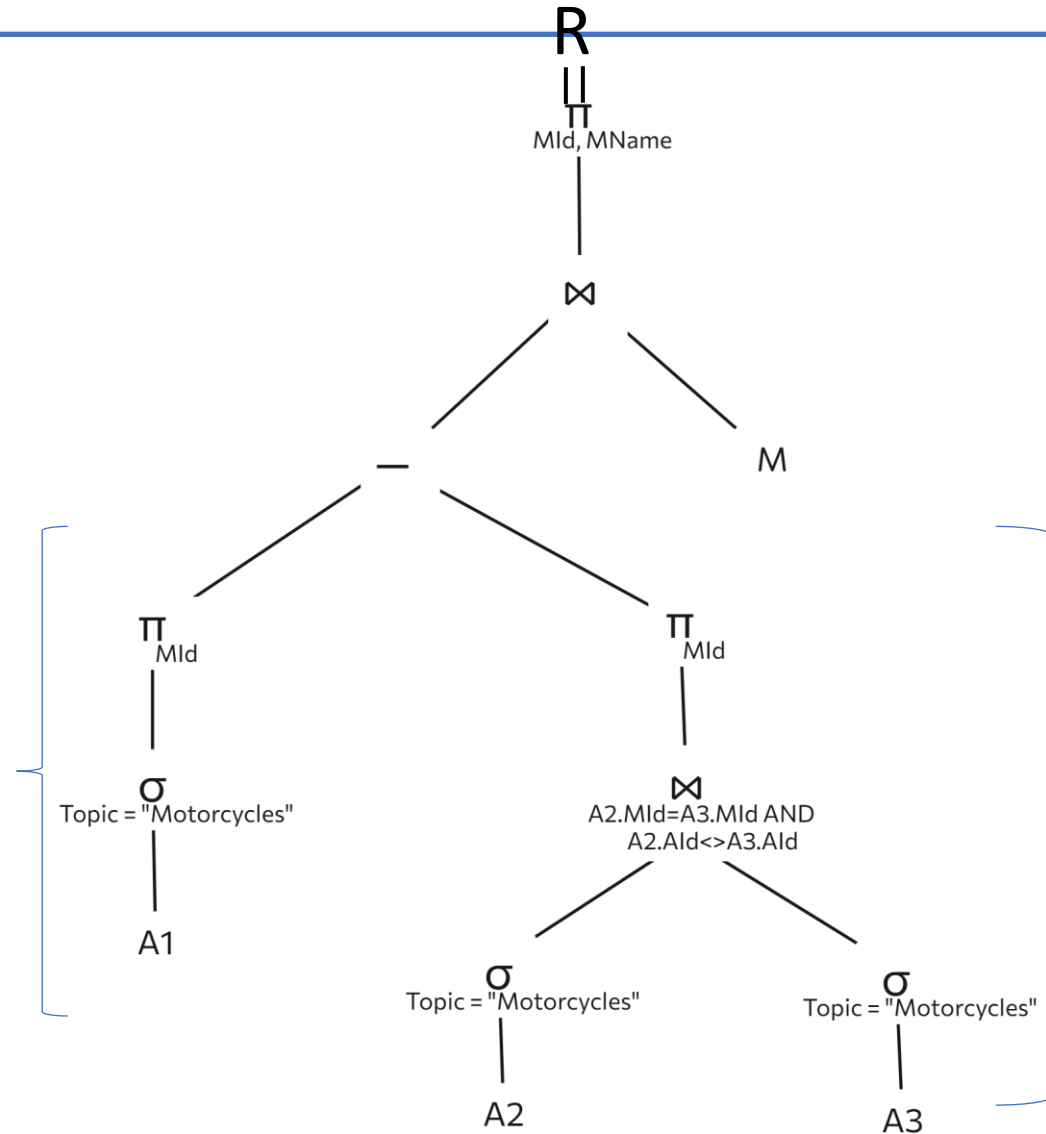

Magazines that have published at least two articles about motorcycling

Exercise 1g

Alternative solutions:

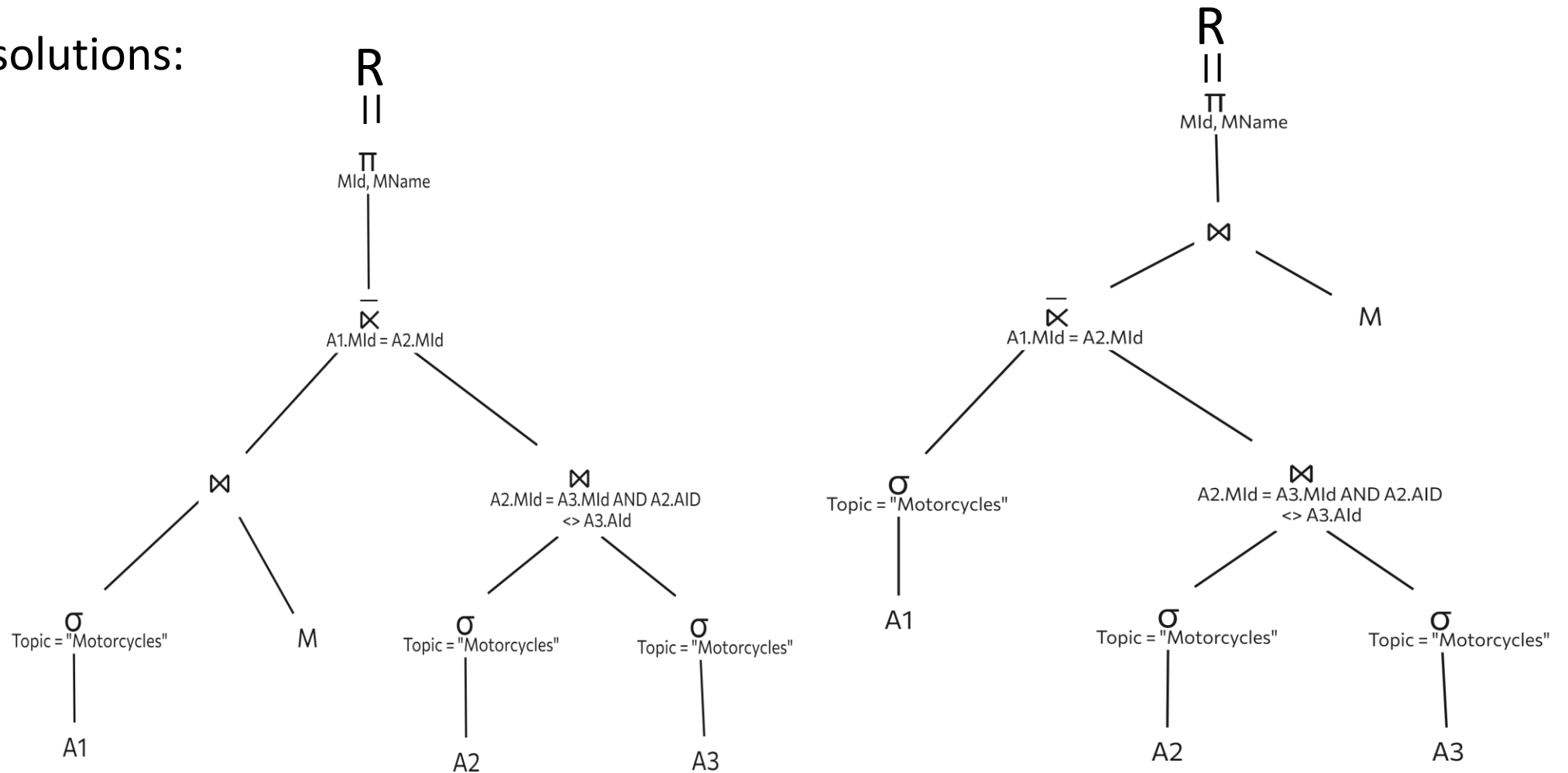



Exercise 2

Exercise 2a

Given the relational schema including the following tables (primary keys are underlined):

SAILOR(SId, SName, Expertise, DateOfBirth)

BOOKING(SId, BId, Date)

BOAT(BId, BName, Color)

Find the names of the sailors who have booked a red boat or a green boat.

Exercise 2a

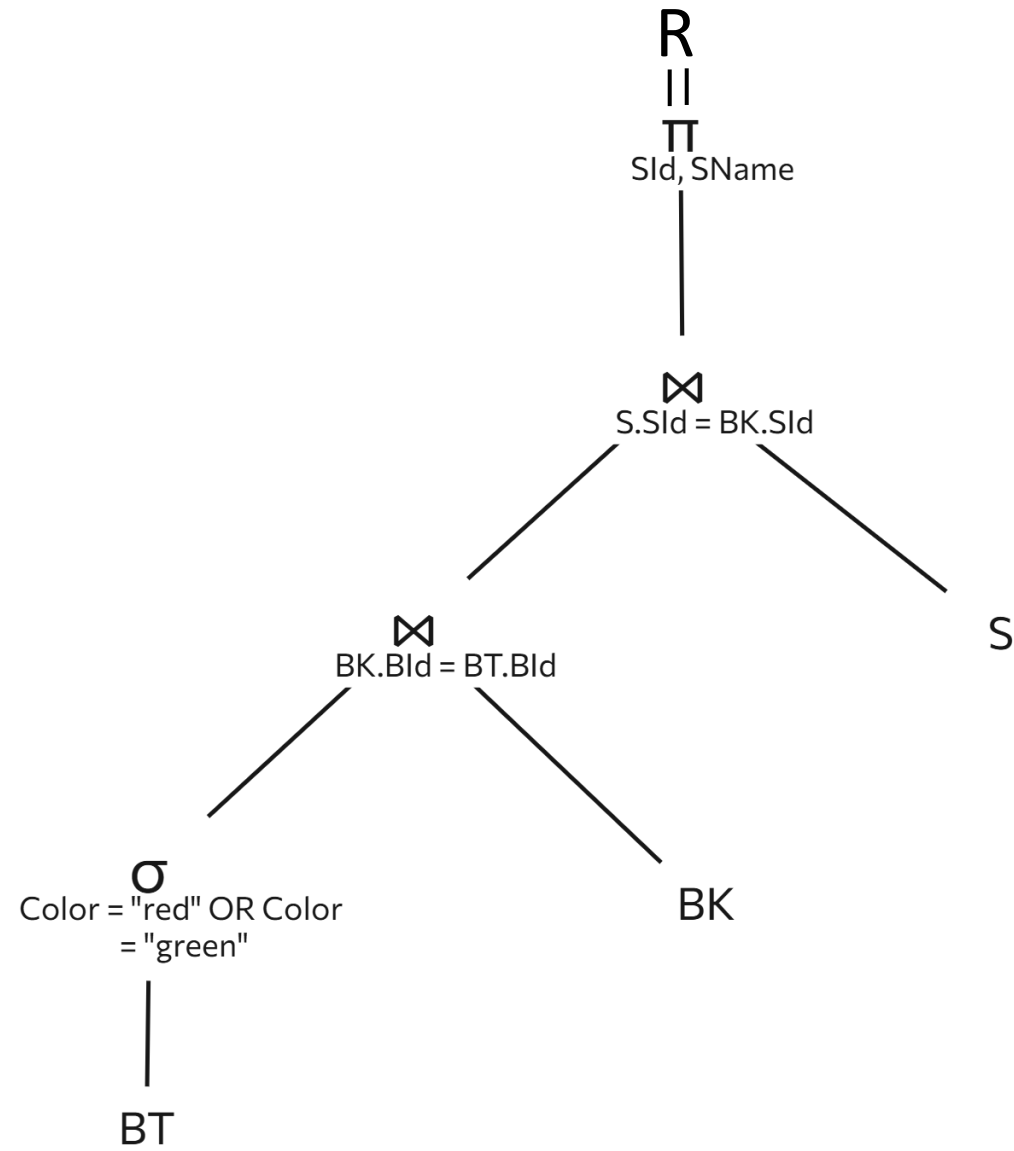

Exercise 2b

Given the relational schema including the following tables (primary keys are underlined):

SAILOR(SId, SName, Expertise, DateOfBirth)

BOOKING(SId, BId, Date)

BOAT(BId, BName, Color)

Find the codes and the names of the sailors who have booked a red boat and a green boat.

Exercise 2b

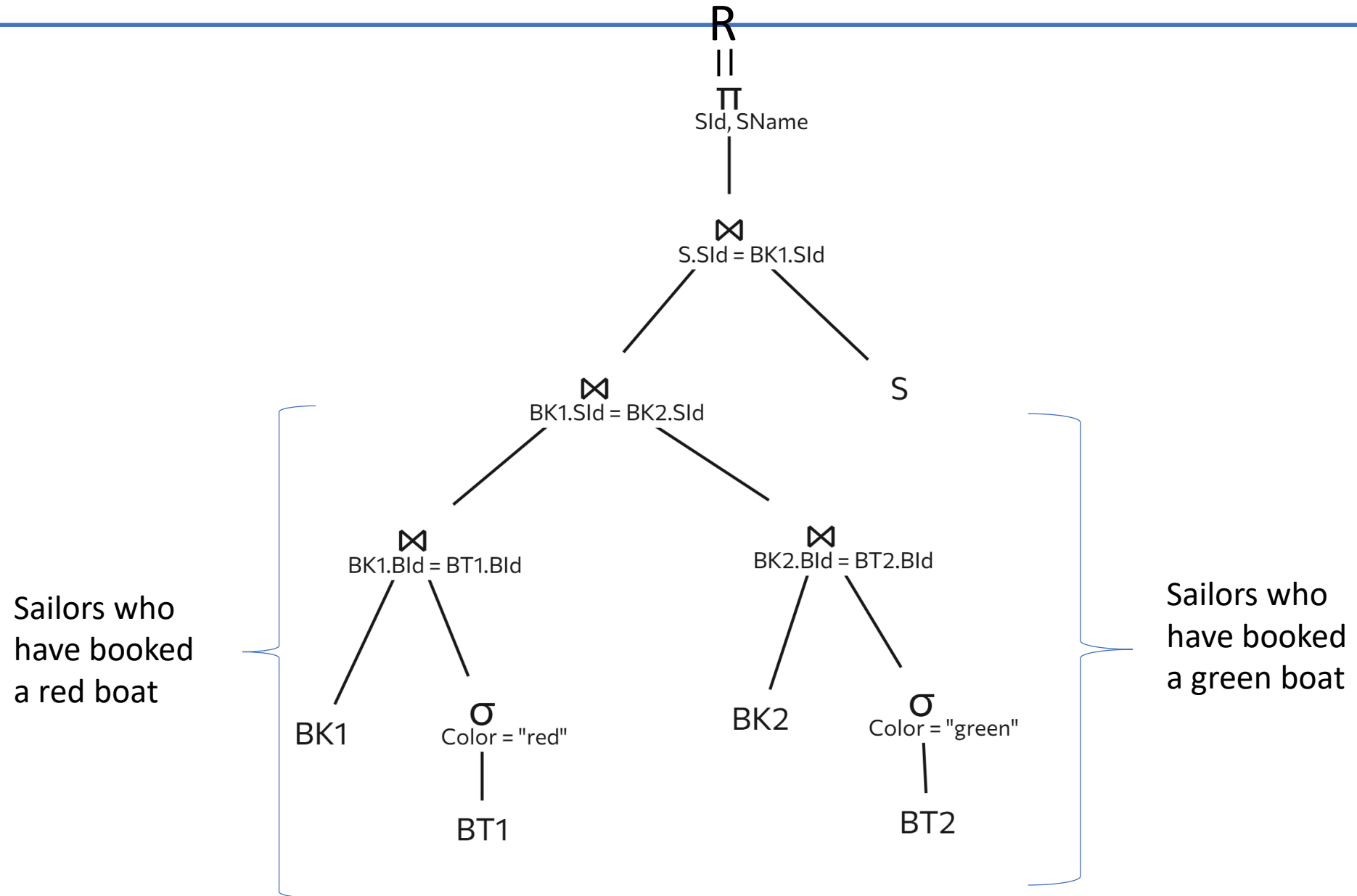

Exercise 2b

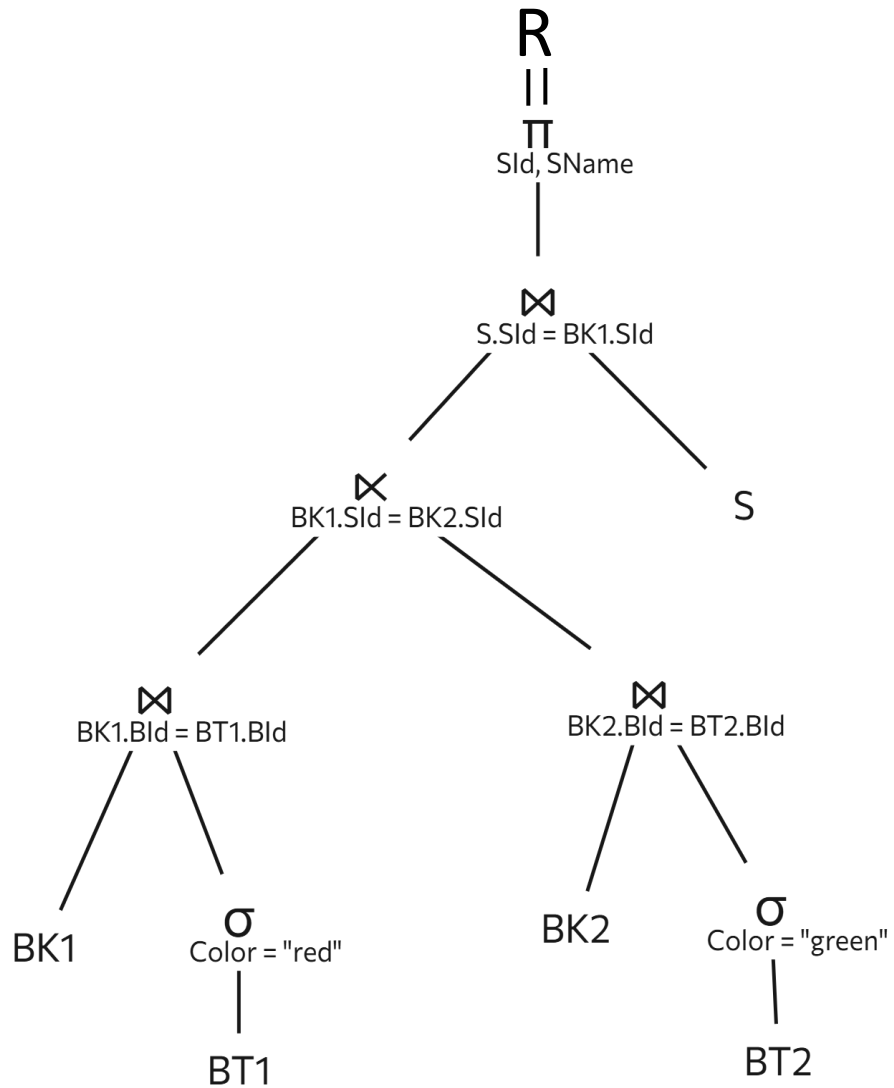

Sailors who
have booked
a red boat

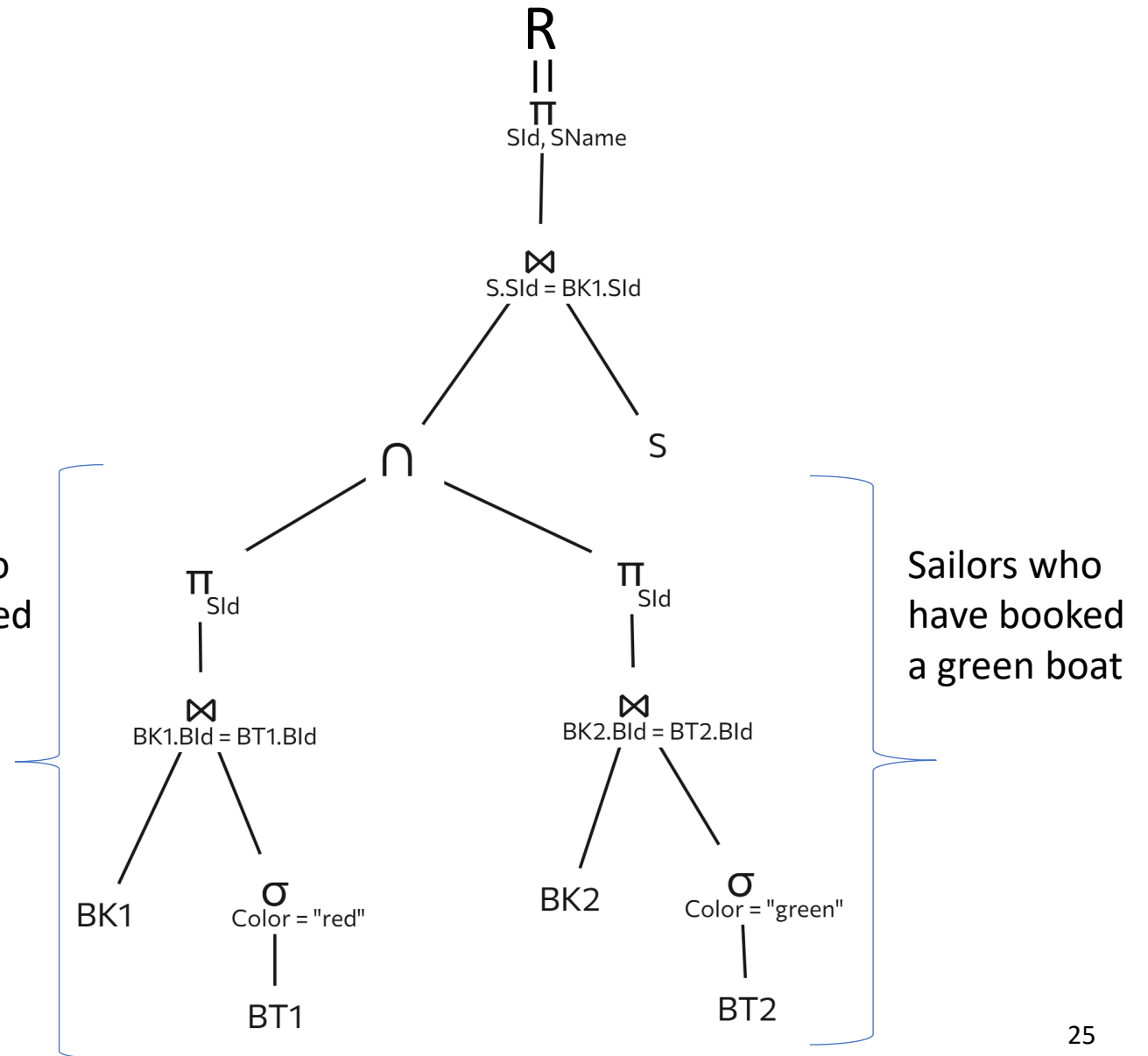

Sailors who
have booked
a green boat

Exercise 2c

Given the relational schema including the following tables (primary keys are underlined):

SAILOR(SId, SName, Expertise, DateOfBirth)

BOOKING(SId, BId, Date)

BOAT(BId, BName, Color)

Find the codes of the sailors who have never booked a red boat

Exercise 2c

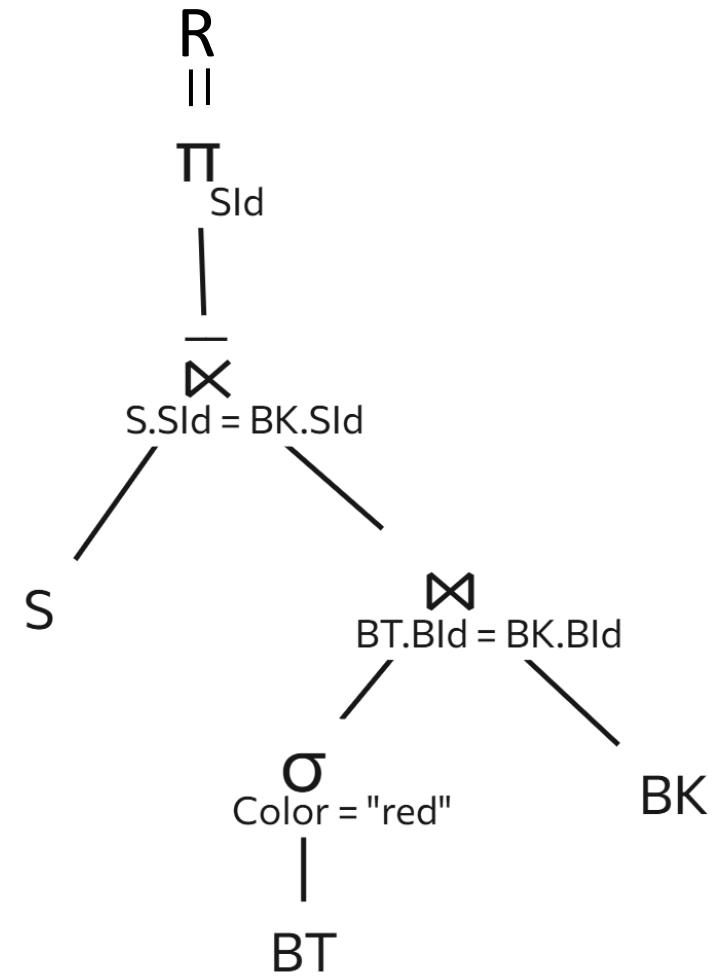
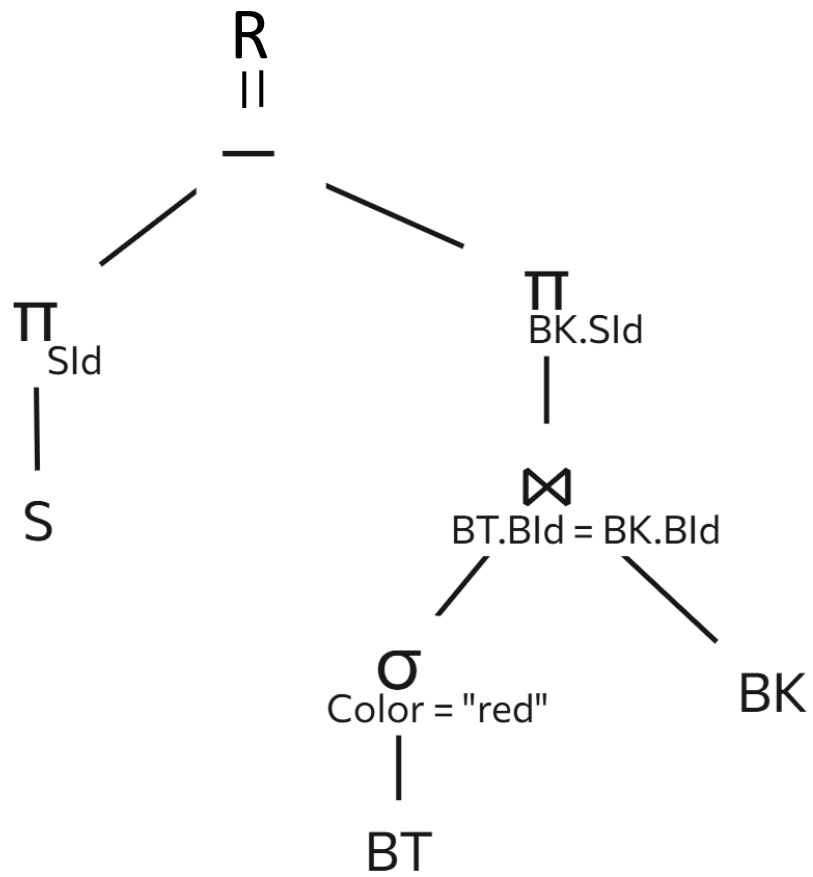

Exercise 2d

Given the relational schema including the following tables (primary keys are underlined):

SAILOR(SId, SName, Expertise, DateOfBirth)

BOOKING(SId, BId, Date)

BOAT(BId, BName, Color)

Find the codes and the names of the sailors who have never booked a red boat

Exercise 2d

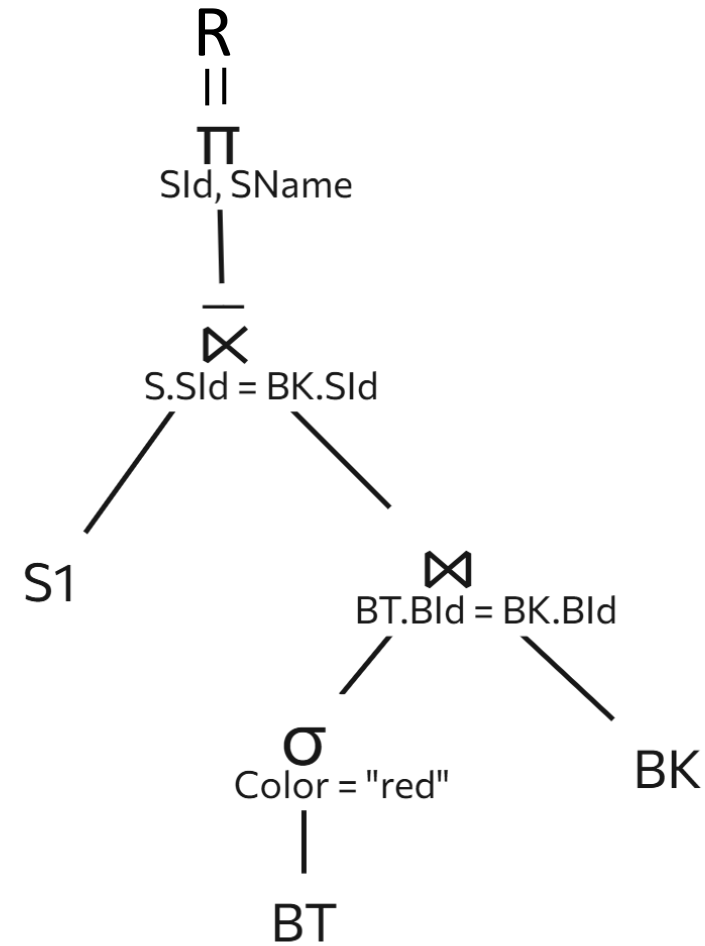
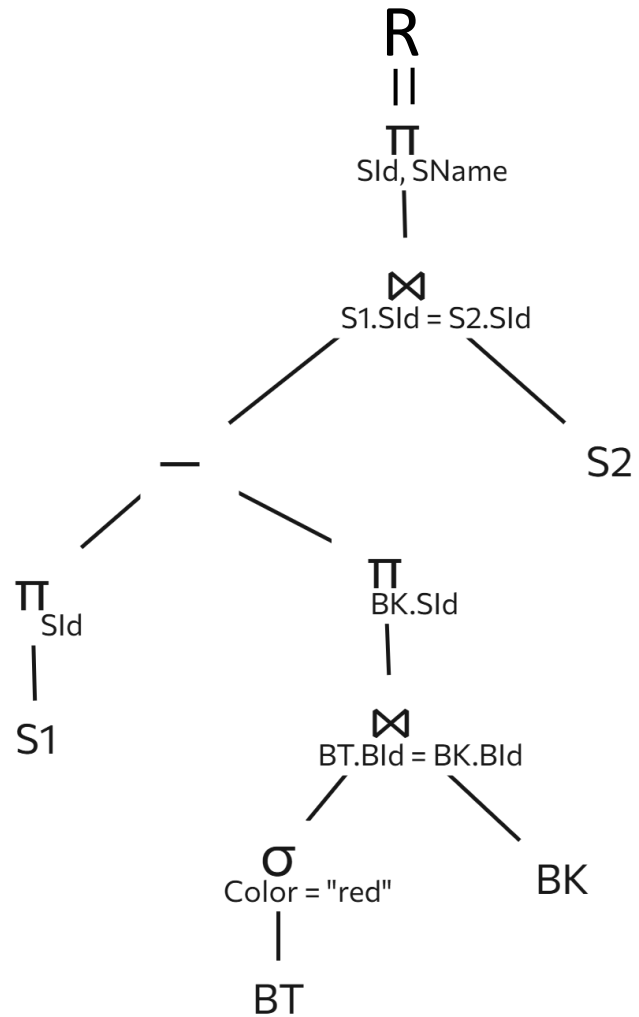

Exercise 2e

Given the relational schema including the following tables (primary keys are underlined):

SAILOR(SId, SName, Expertise, DateOfBirth)

BOOKING(SId, BId, Date)

BOAT(BId, BName, Color)

Find the codes and the names of the sailors who have booked at least two boats.

Exercise 2e

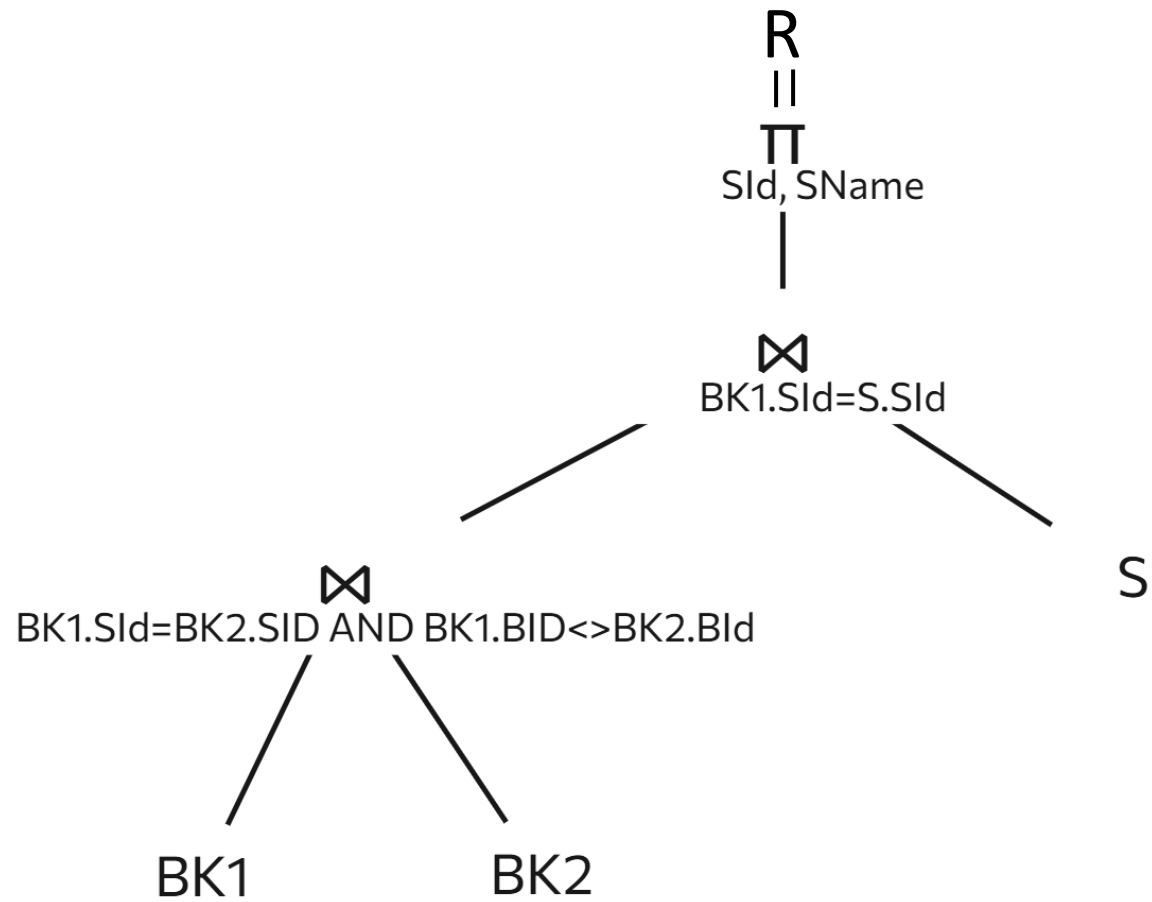

Exercise 2f

Given the relational schema including the following tables (primary keys are underlined):

SAILOR(SId, SName, Expertise, DateOfBirth)

BOOKING(SId, BId, Date)

BOAT(BId, BName, Color)

Find the codes and the names of the sailors who have booked at least three boats.

Exercise 2f

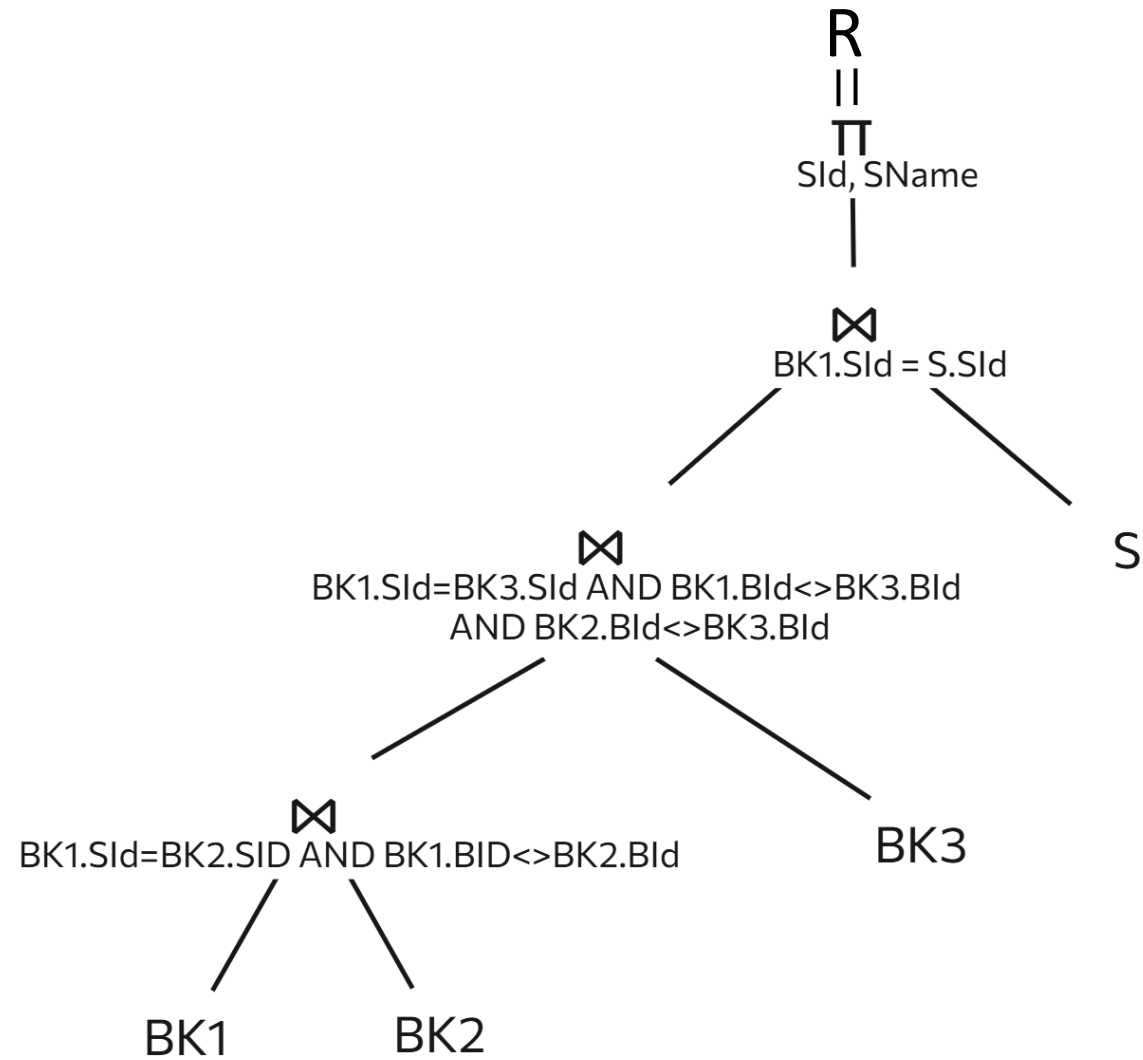



Politecnico
di Torino

DBG
MG

Exercise 3

Exercise Aircraft 3a

Given the following relational schema (primary keys are underlined, optional attributes are denoted with '*'):

AIRCRAFT(AId, AName, MaximumRange)

CERTIFICATE(PIId, AId)

PILOT(PIId, PName, Salary)

Find the codes and the names of the pilots who are qualified to fly on an aircraft that can cover distances greater than 5,000 km (MaximumRange \geq 5,000).

Exercise Aircraft 3a

aircrafts that can cover distances greater than 5,000 km
(MaximumRange \geq 5,000)

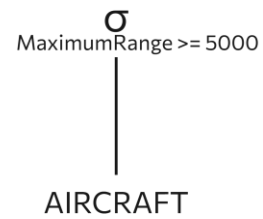

pilots who are qualified to fly
(natural join on Ald)



CERTIFICATE

Exercise Aircraft 3a

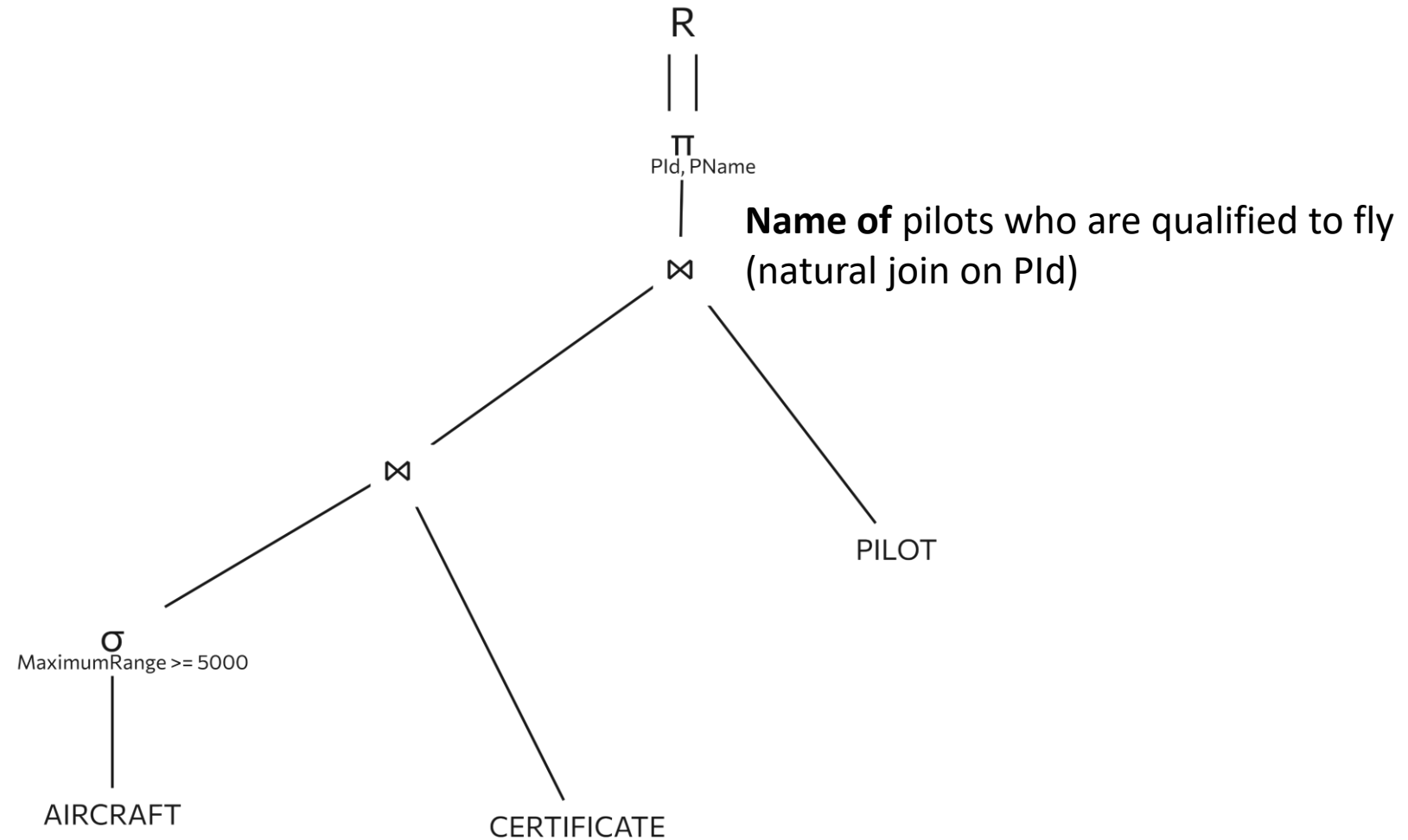

Exercise 3b

Given the relational schema including the following tables (primary keys are underlined):

AIRCRAFT(AId, AName, MaximumRange)

CERTIFICATE(PIId, AId)

PILOT(PIId, PName, Salary)

Find the codes and the names of the pilots who are qualified to fly on at least two aircrafts that can cover distances greater than 5,000 km.

Exercise 3b

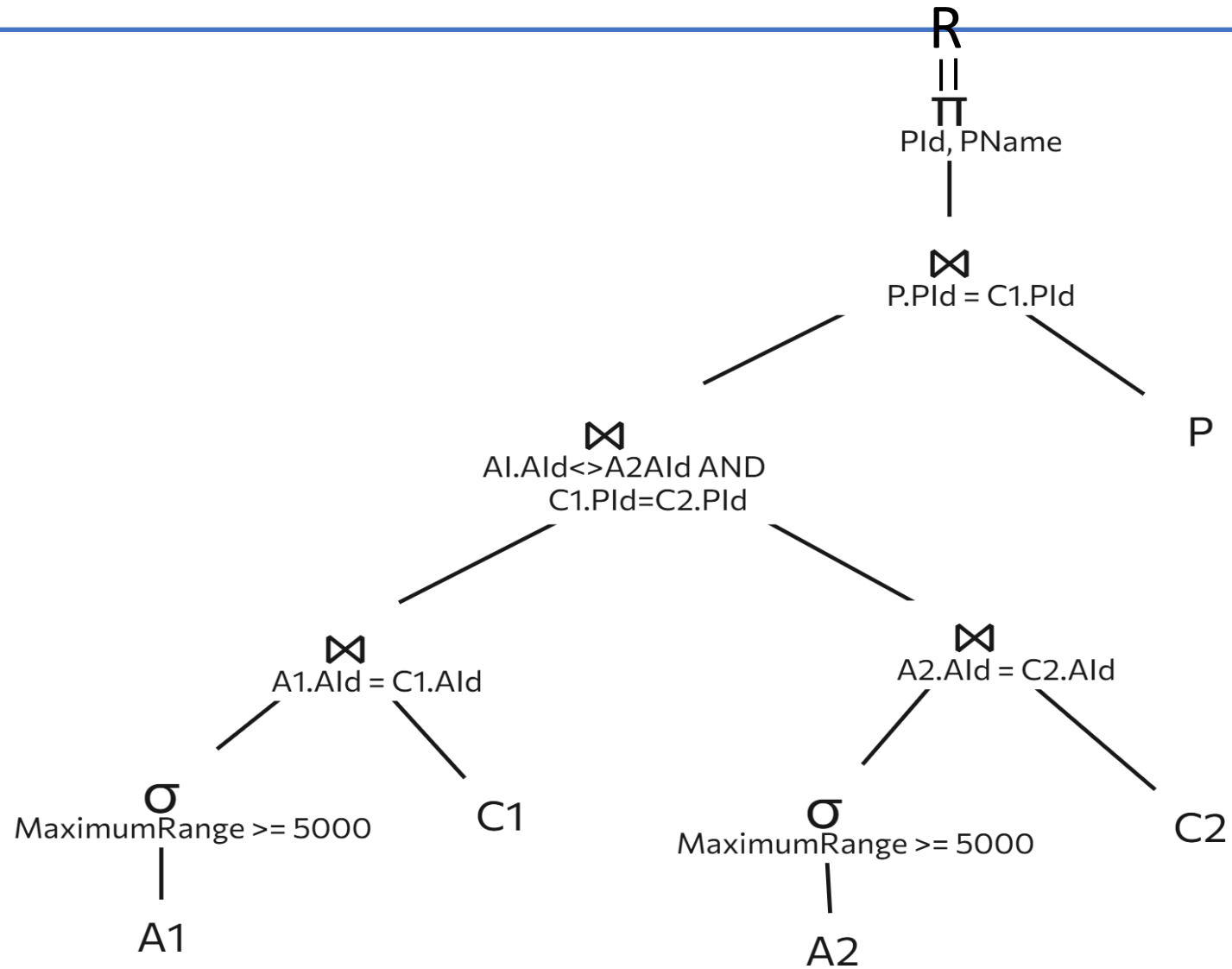

Exercise Aircraft 3c

Given the following relational schema (primary keys are underlined, optional attributes are denoted with '*'):

AIRCRAFT(Aid, AName, MaximumRange)

CERTIFICATE(PId, Aid)

PILOT(PId, PName, Salary)

Find the codes and the names of the pilots who are qualified to fly on at least two aircrafts that can cover distances greater than 5,000 km, and who are qualified to fly on a Boeing.

Exercise Aircraft 3c

Pilots who are qualified to fly
aircrafts that can cover distances
greater than 5,000 km
(MaximumRange \geq 5,000)

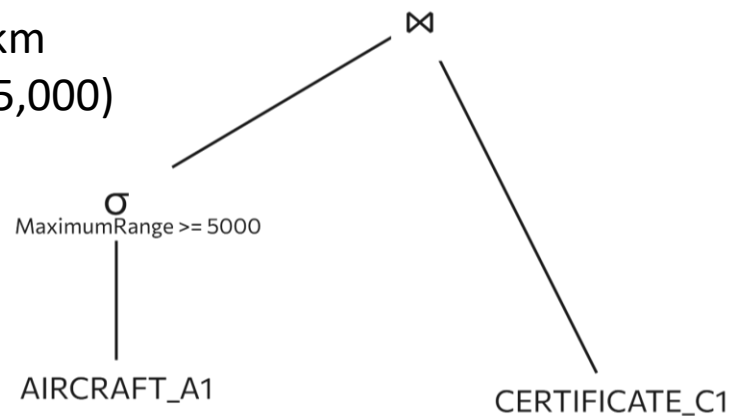

Exercise Aircraft 3c

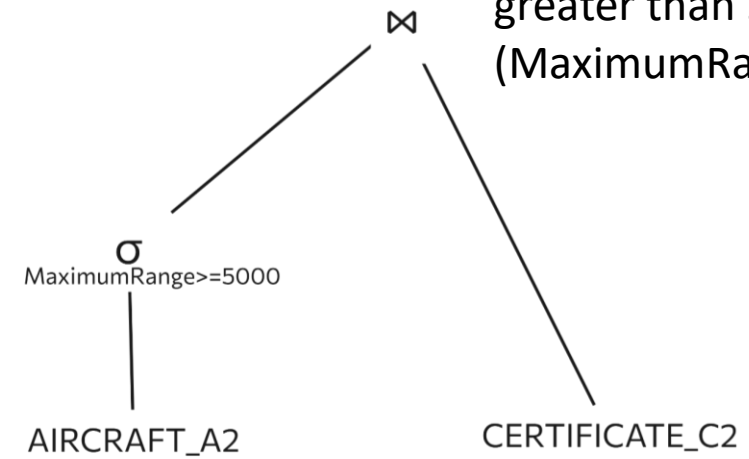
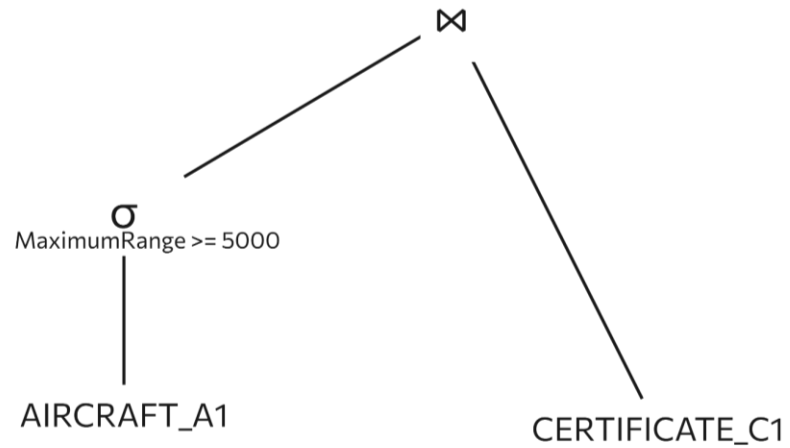

Pilots who are qualified to fly aircrafts that can cover distances greater than 5,000 km (MaximumRange \geq 5,000)

Exercise Aircraft 3c

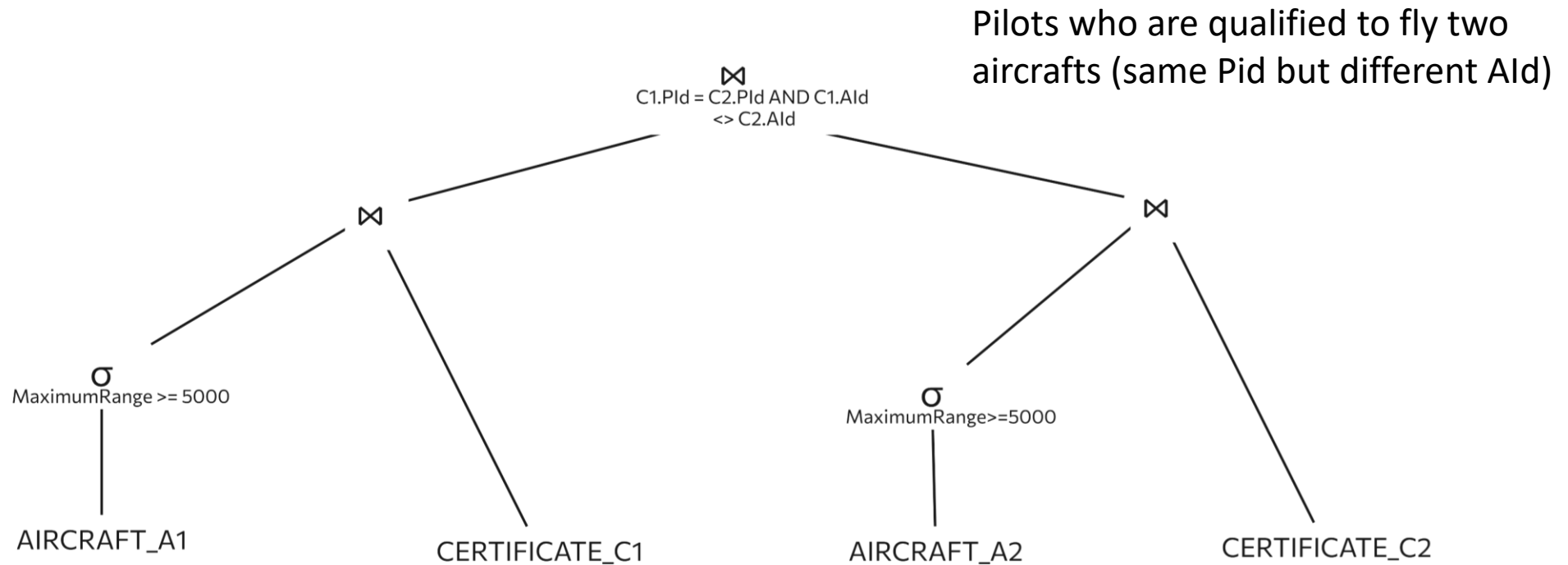

Exercise Aircraft 3c

Pilots who are qualified to fly Boeing aircrafts
(regardless of the maximum range attribute)

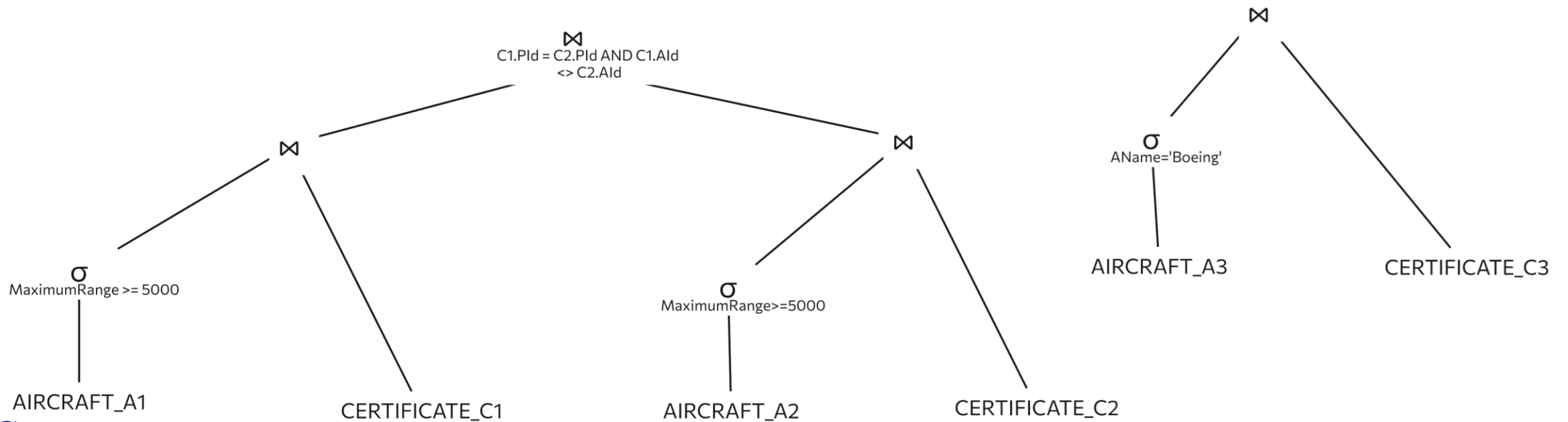

Exercise Aircraft 3c

Select pilots who have all three certifications simultaneously (C1.Pid = C2.Pid = C3.Pid).

Alternative solutions:

- Semi-join
- Projection + Intersection

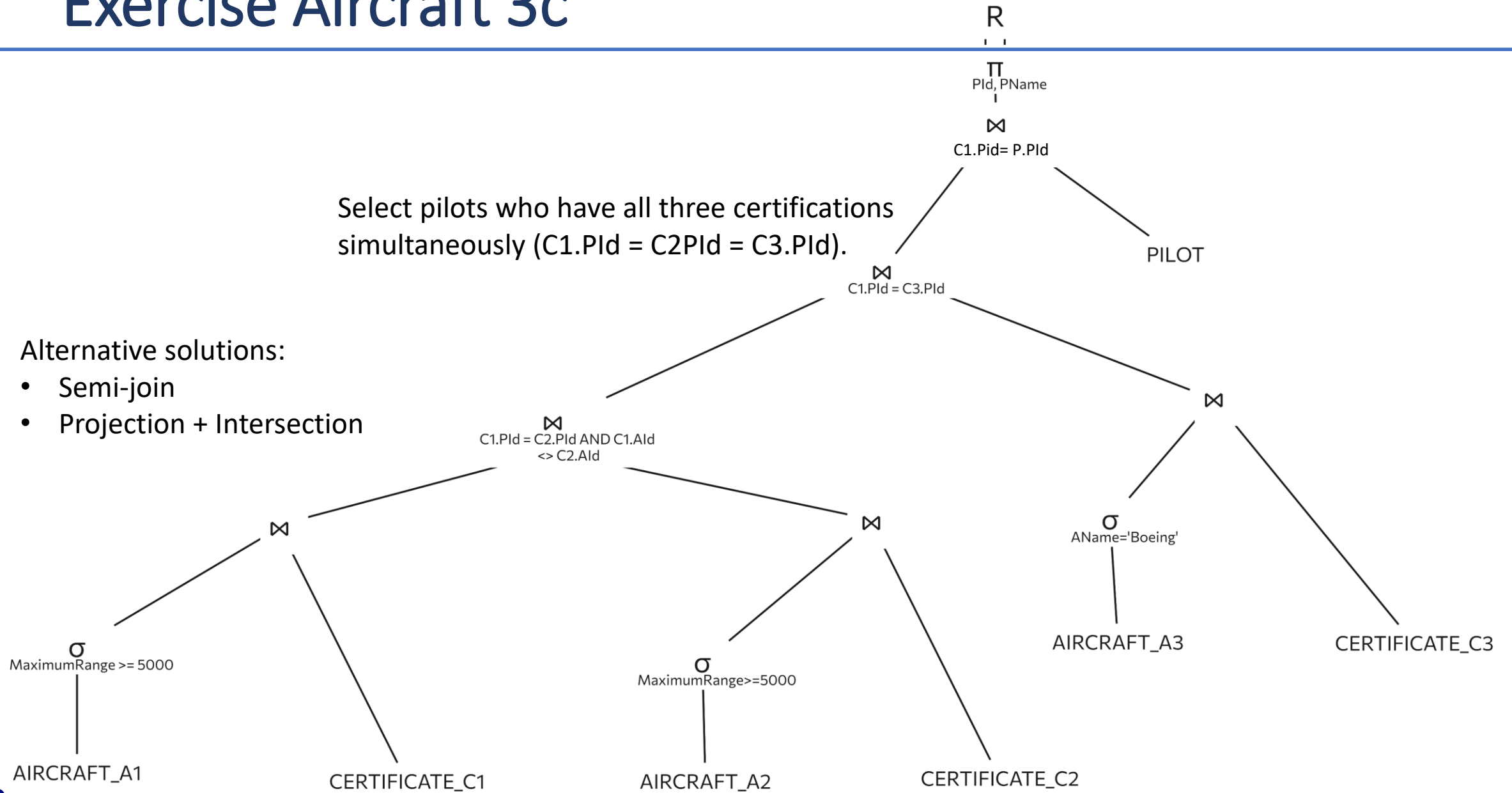

Exercise 3c

Alternative solution:

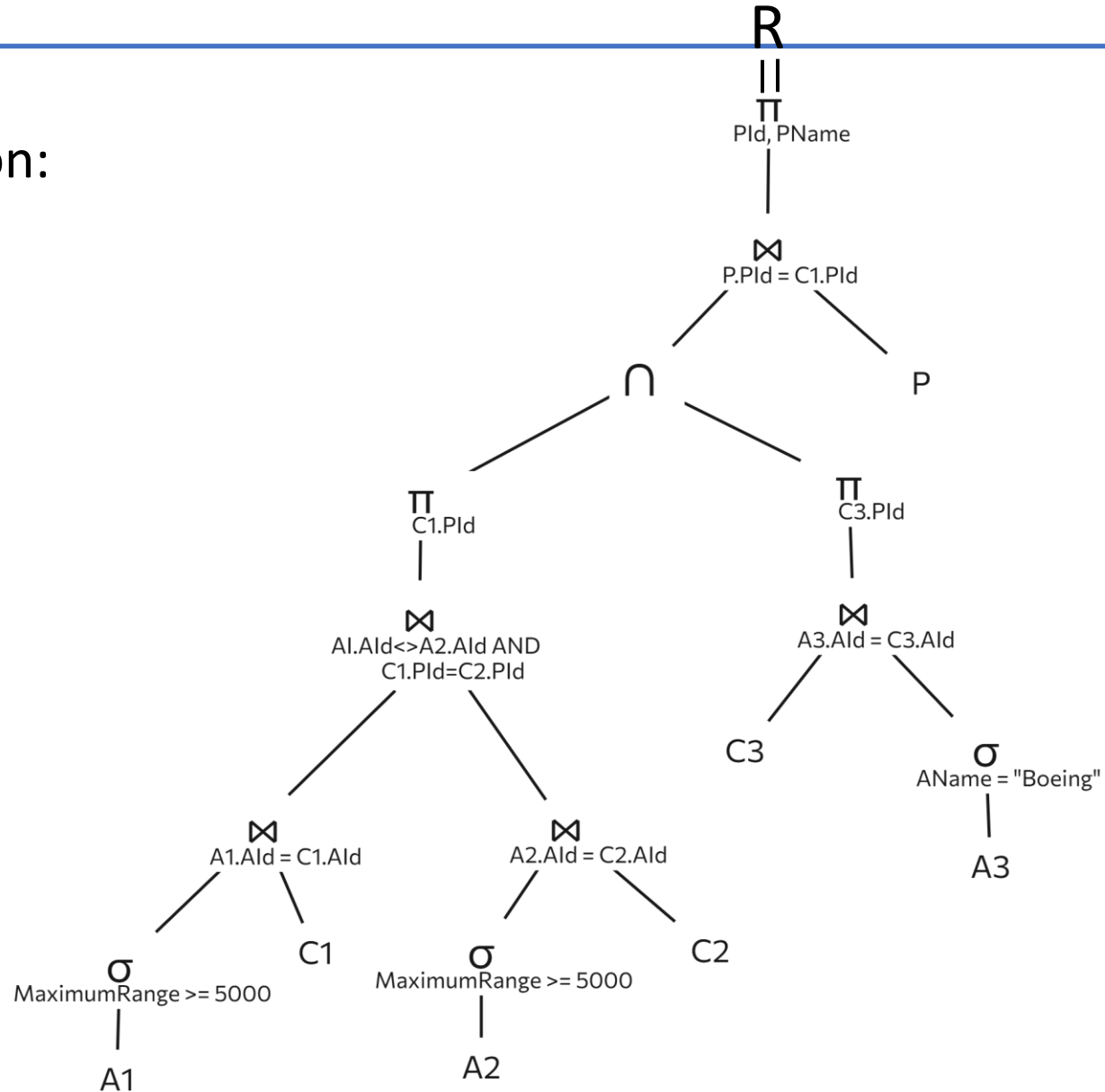



Politecnico
di Torino

DBG
MG

Other

Exercise 1

Given the following relational schema (primary keys are underlined, optional attributes are denoted with '*'):t

DIRECTOR(DirID, Name, Surname, Nationality)

FILM (FilmID, Title)

AWARD (AwardID, NameAward)

WINNERS (AwardID, DirID, Year, FilmID)

Display the name of Italian directors such that at least one of their films has won both the award for best soundtrack (attribute NameAward) and the award for best screenplay in the same year.

Exercise 1

The following query tree graphs the requested algebraic query. For each of the boxes in the query tree (i.e. boxes A, B, C, D, E, F, G, H, I, L, M), you are asked to indicate the corresponding relation or algebraic operator (with any associated predicate). Use the text box below to report the solution. Note: Each box in the query tree has only one relationship or algebraic operator associated with it.

DIRECTOR(DirID, Name, Surname,
Nationality)

FILM (FilmID, Title)

AWARD (AwardID, NameAward)

WINNERS (AwardID, DirID, Year, FilmID)

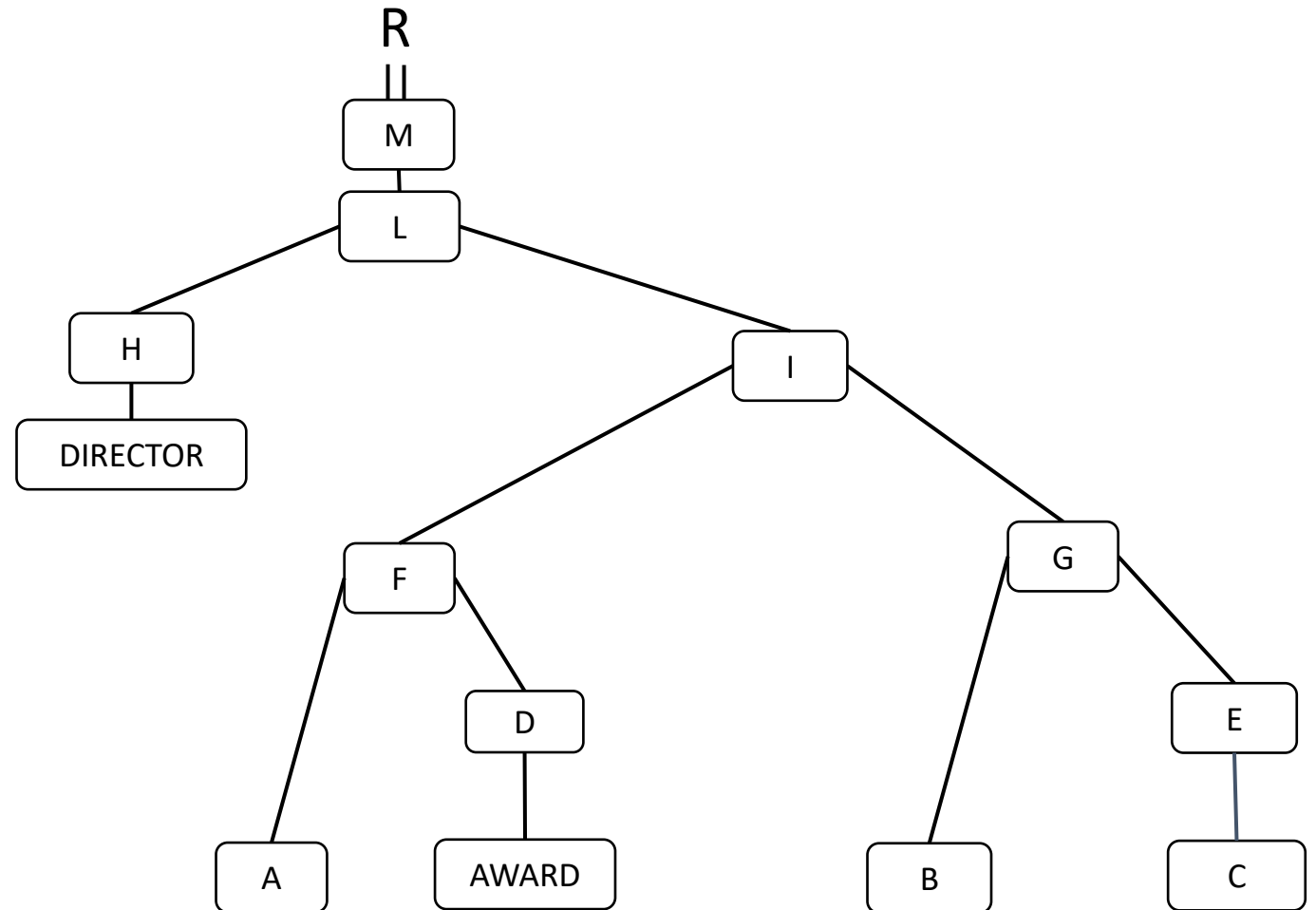

Exercise 1

Display the name of Italian directors such that at least one of their films has won both the award for best soundtrack (attribute NameAward) and the award for best screenplay in the same year.

DIRECTOR(DirID, Name, Surname,
Nationality)

FILM (FilmID, Title)

AWARD (AwardID, NameAward)

WINNERS (AwardID, DirID, Year, FilmID)

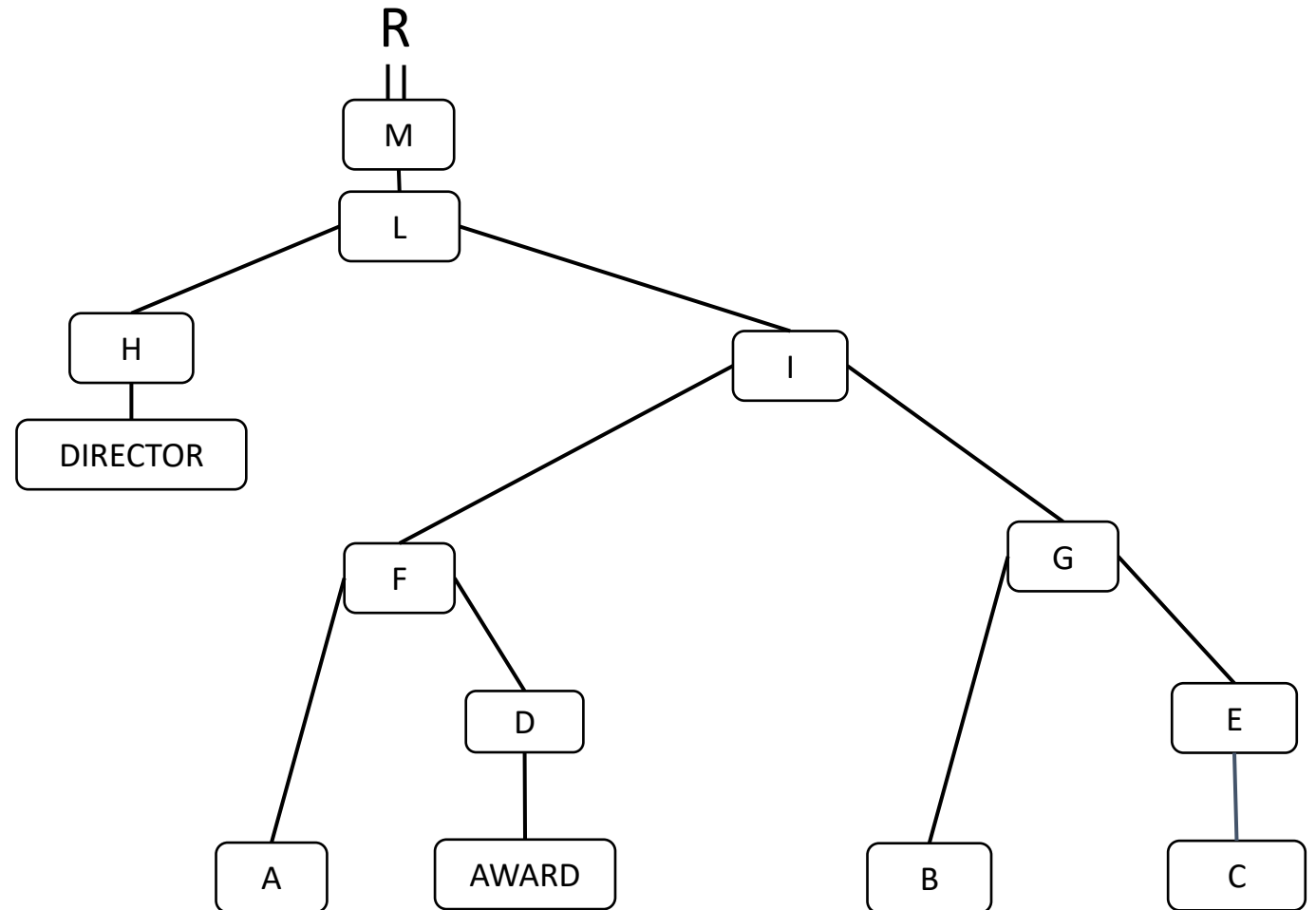

Exercise 1

Display the name of Italian directors such that at least one of their films has won both the award for best soundtrack (attribute NameAward) and the award for best screenplay in the same year.

DIRECTOR(DirID, Name, Surname,
Nationality)

FILM (FilmID, Title)

AWARD (AwardID, NameAward)

WINNERS (AwardID, DirID, Year, FilmID)

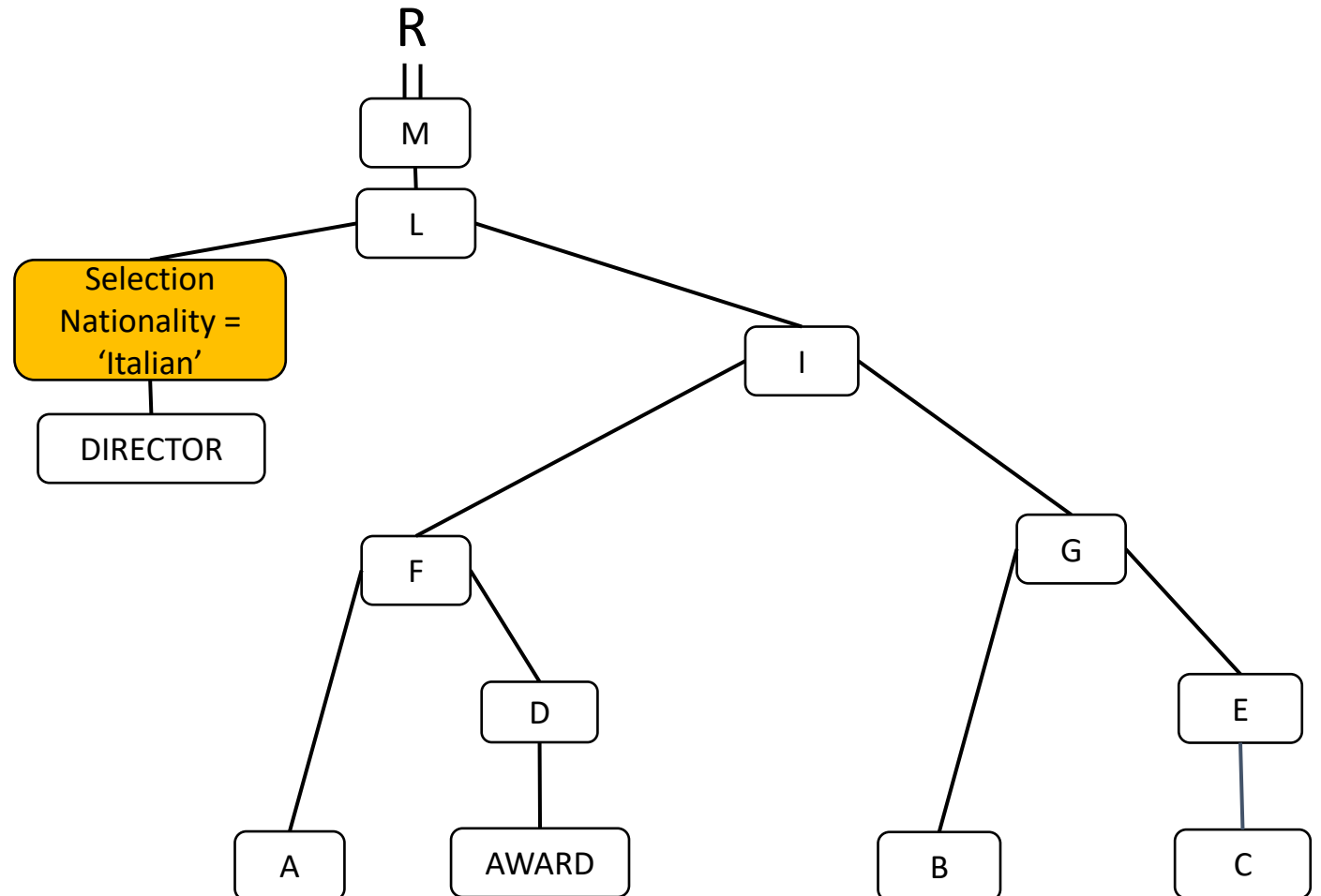

Exercise 1

Display the name of Italian directors such that at least one of their films has won both the award for best soundtrack (attribute NameAward) and the award for best screenplay in the same year.

DIRECTOR(DirID, Name, Surname,
Nationality)

FILM (FilmID, Title)

AWARD (AwardID, NameAward)

WINNERS (AwardID, DirID, Year, FilmID)

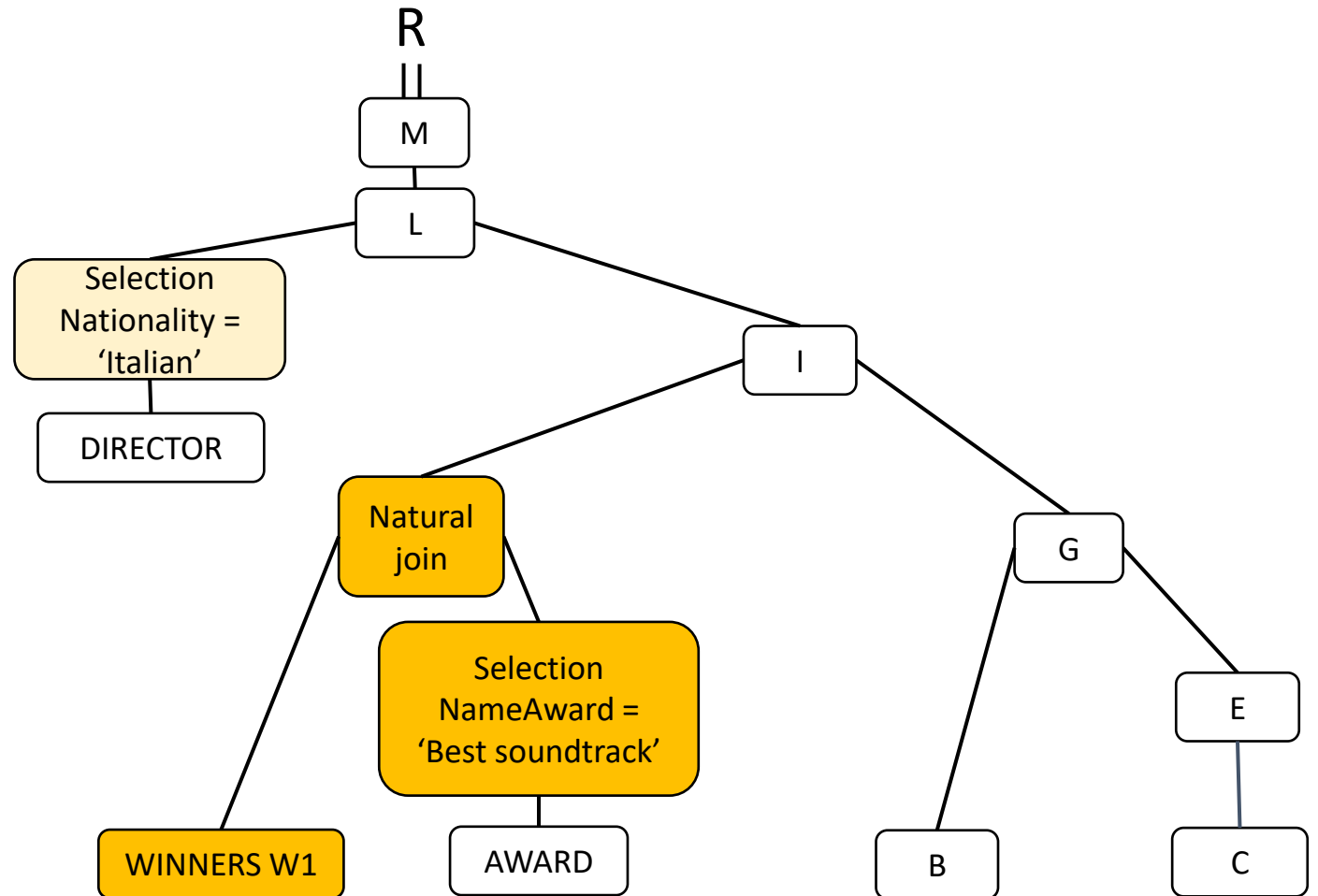

Exercise 1

Display the name of Italian directors such that at least one of their films has won both the award for best soundtrack (attribute NameAward) and the award for best screenplay in the same year.

DIRECTOR(DirID, Name, Surname,
Nationality)

FILM (FilmID, Title)

AWARD (AwardID, NameAward)

WINNERS (AwardID, DirID, Year, FilmID)

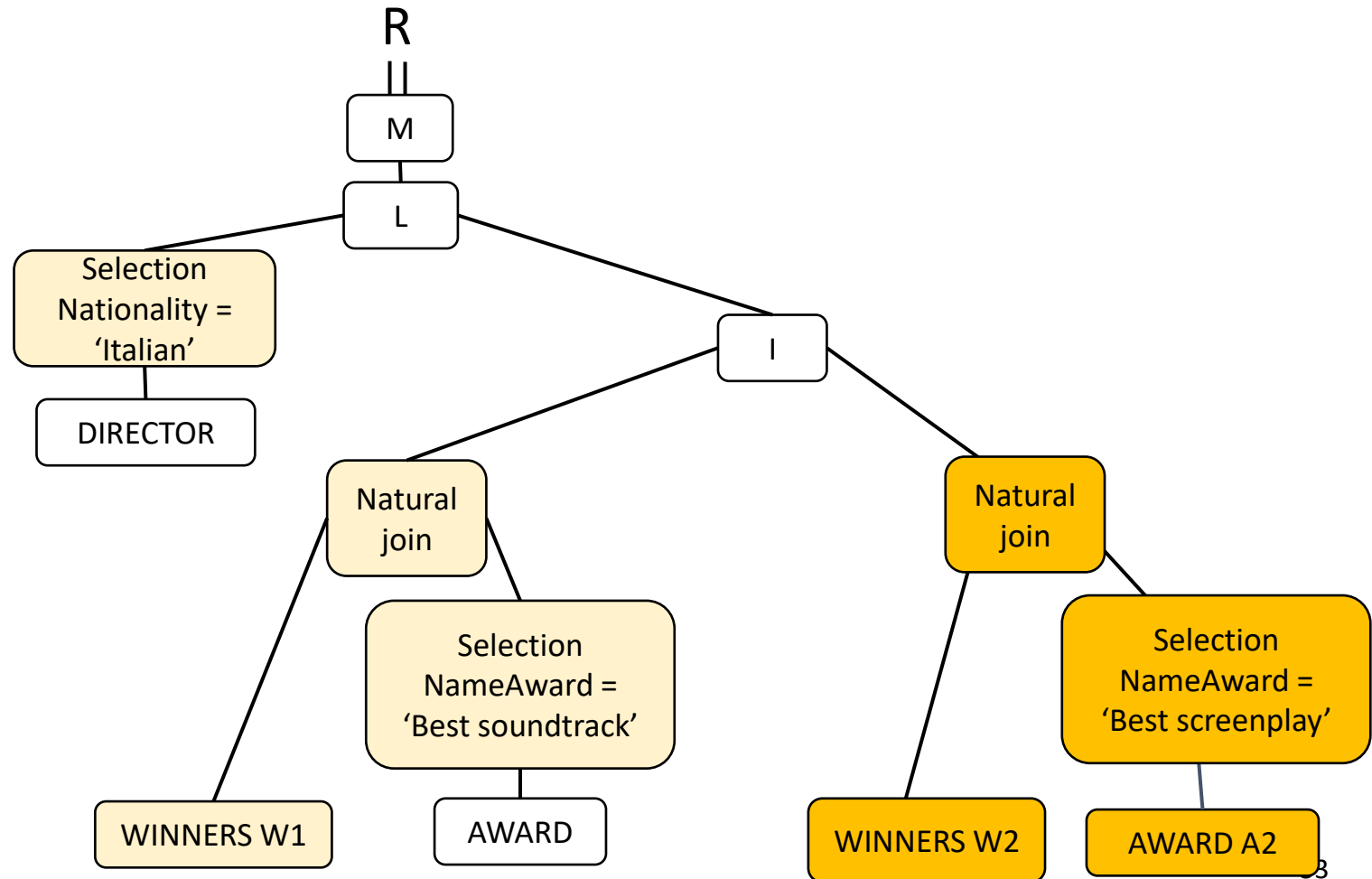

Exercise 1

Display the name of Italian directors such that at least one of their films has won both the award for best soundtrack (attribute NameAward) and the award for best screenplay in the same year.

DIRECTOR(DirID, Name, Surname,
Nationality)

FILM (FilmID, Title)

AWARD (AwardID, NameAward)

WINNERS (AwardID, DirID, Year, FilmID)

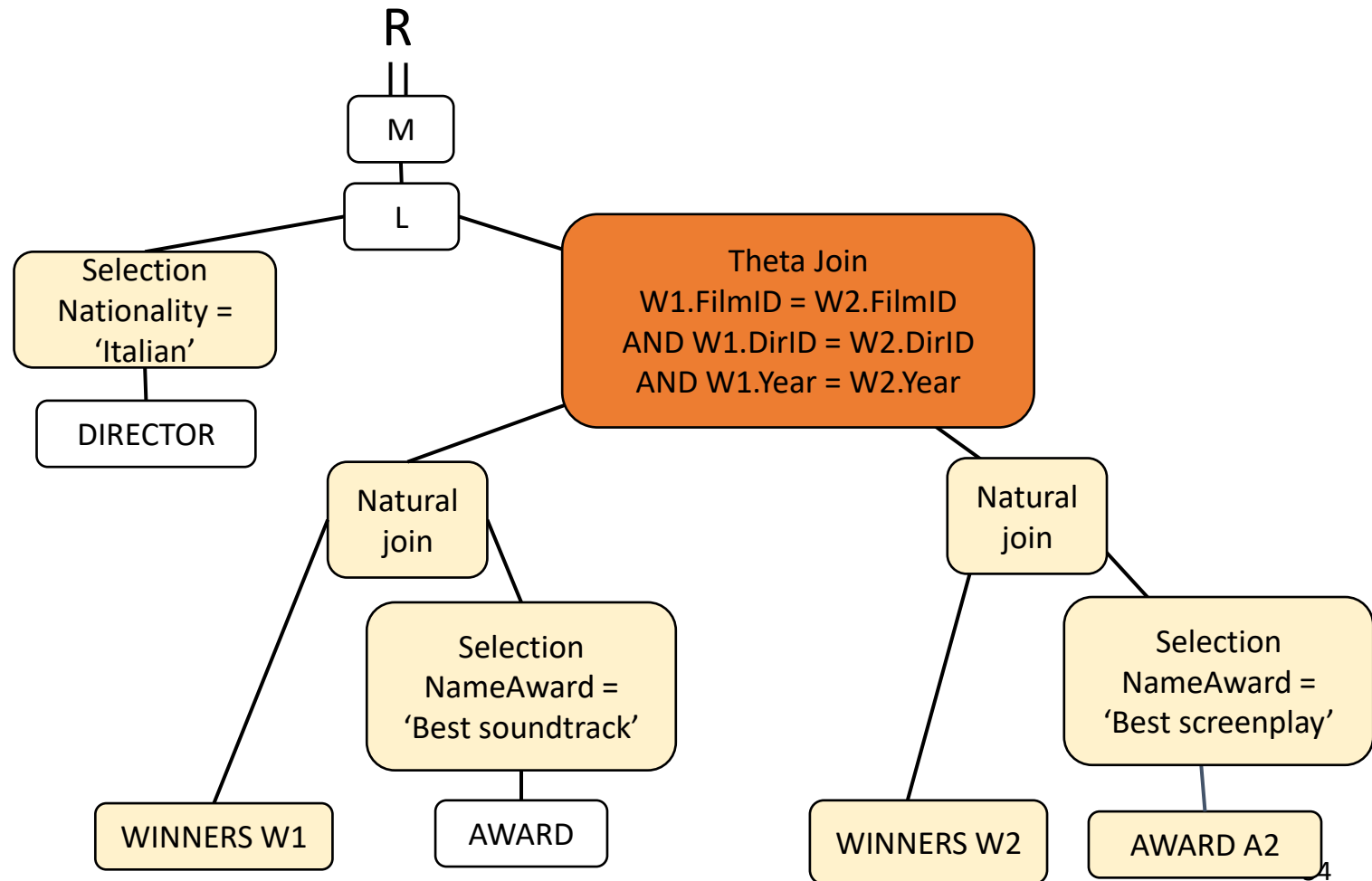

Exercise 1

Display the name of Italian directors such that at least one of their films has won both the award for best soundtrack (attribute NameAward) and the award for best screenplay in the same year.

DIRECTOR(DirID, Name, Surname,
Nationality)

FILM (FilmID, Title)

AWARD (AwardID, NameAward)

WINNERS (AwardID, DirID, Year, FilmID)

